



**Haskel**  
MILTON ROY

PNEUMATIC DRIVEN LIQUID PUMPS

PERFORMANCE • QUALITY • RELIABILITY





## Welcome to Haskel

Haskel is an international organization offering a worldwide service through the Haskel group of companies and factory trained distributors. The Haskel group is headquartered in Burbank, California, with facilities throughout the world. We have built an enviable reputation for quality based on high pressure fluid and gas handling equipment.

In addition to offering a comprehensive range of pneumatic driven liquid pumps, air amplifiers, pneumatic and hydraulic driven gas boosters, high pressure valves, fittings and accessories, we custom design and build power pacs and test rigs. Our continued investment in technology ensures that Haskel will stay at the leading edge of high pressure technology.

This brochure introduces our pneumatic driven liquid pump range. Technical details and advice on any of the products shown is available on request.

We are here to solve your problems. Just give us a call at 818-843-4000 or visit our website at [www.haskel.com](http://www.haskel.com) for more information or to locate a distributor.

## Why Use Haskel Pneumatic Driven Pumps?

*Our pumps offer many advantages over electrically driven pumps:*

- Safe pneumatic operation – no heat, flame or spark risk
- Up to 100,000 psi (7000 bar) capability
- Infinitely variable cycling speed
- Stall feature at pre-determined pressure to hold that pressure without consuming power
- Problem-free stop/start applications
- Easily automated – many modification and control options
- Suitable for most liquids and liquefied gases
- Alternative gas drive options – sour gas, natural gas, boil off gases, nitrogen
- No need for air line lubrication – saves costs and prevents contamination
- Robust, reliable, compact and easy to maintain proven design
- Unbalanced cycling spool provides immediate response to pressure changes
- Also available in standard, or custom built power pac configurations
- Excellent worldwide service for spares and repairs
- Can be manufactured to meet ATEX, CE and NACE

## Applications include:

- Pressure testing
- Work holding/power clamping
- Jacking/lifting
- Valve actuator control
- Hydraulic cylinder actuation
- Press safety overload devices
- Roller tensioning
- Metering
- Precision lubrication and spraying
- Liquefied gas transfer



## Pressure and Flow on Demand

This guide will help you to pre-select the pump ideally suited for your application. If you have specific questions, however, we urge you to provide Haskel with the operational details of your application. We will recommend a model and any corresponding accessories.

## Output Horsepower Ratings

The pumps are categorized on their horsepower ratings (see pages 6-7). These are approximate and peak at 100 psi (7 bar), assuming adequate drive, pressure and volume. Peak horsepower is at about 75% nominal ratio x drive pressure, i.e. 100:1 pump @ 100 psi air drive peaks at  $100 \times 100 = 10000 \times 0.75$  psi = 7500 psi (517 bar) hydraulic pressure.

## Operation

The pumps automatically reciprocate on a differential piston principle. A large piston driven by relatively low pressure drive acts directly upon a smaller hydraulic piston.

The nominal ratio between piston sizes is indicated in the model coding and approximates to the maximum working pressure. The actual ratio is about 15% above nominal so that the pump continues to cycle when drive pressure equals nominal ratio. Initially, the pump will cycle at maximum speed acting as a transfer pump to pressurize downstream.

It will cycle at a slower rate as the fluid meets resistance until it stalls at maximum output pressure. When a pressure drop downstream occurs, it will recycle as necessary in an effort to maintain maximum pressure. Stall pressure is achieved when the outlet pressure rises and offers more resistance to the reciprocating differential piston assembly. The piston assembly then stalls when the forces balance, e.g. when drive pressure x drive piston area equals outlet (stall) pressure x driven hydraulic plunger area. The pump design is sensitive to very small pressure drops due to the low frictional resistance of the large diameter drive piston and hydraulic piston seals.

## Double and Triple Air Head Pumps

Performance can be extended for the 1.5 hp pumps by stacking air pistons without changing the hydraulic piston. Haskel multi-head pumps consume less air than competitive single head pumps of the same area, as only one head is pressurized on the return stroke; e.g., on a 1.5 hp pump additional heads can raise performance to 2 hp.

Double air head pumps are identified by the last digit 2 in the pump model number. Thus, a nominal 50:1 ratio pump with two air heads is described as a 52. Similarly, a triple air head pump is identified with a last digit 3. Thus, a 900 ratio pump with three air heads is described as a 903.

### Single Drive Head Pump

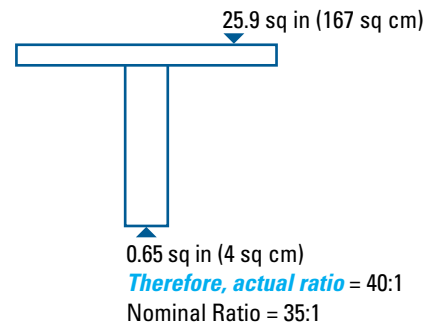

### Double Air Head Pump

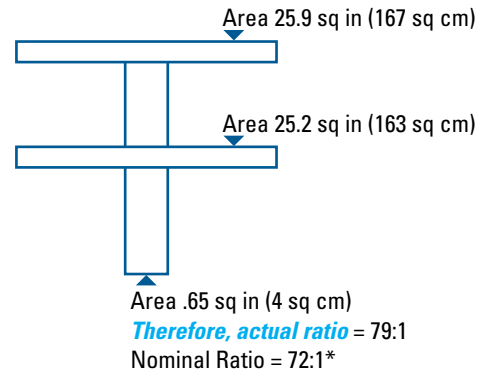

### Triple Air Head Pump

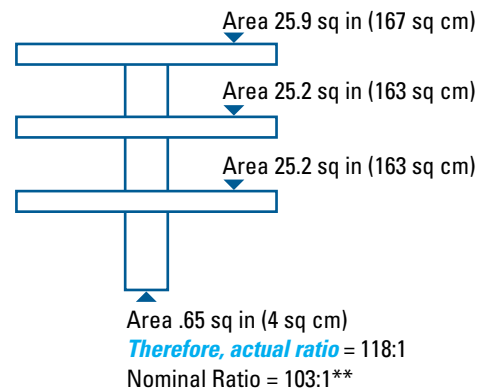

#### Nominal Ratio

\* (2) Indicates Double Drive Piston

\*\* (3) Indicates Triple Drive Piston

1. Drive Section

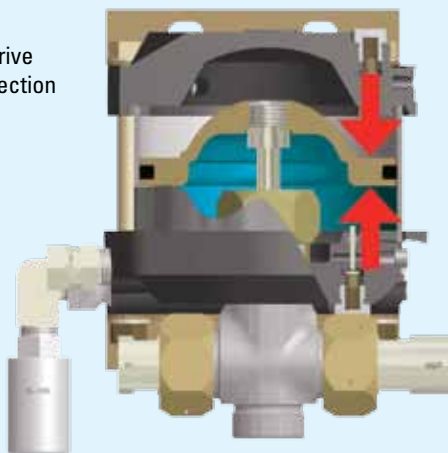

2. Hydraulic Check Valves

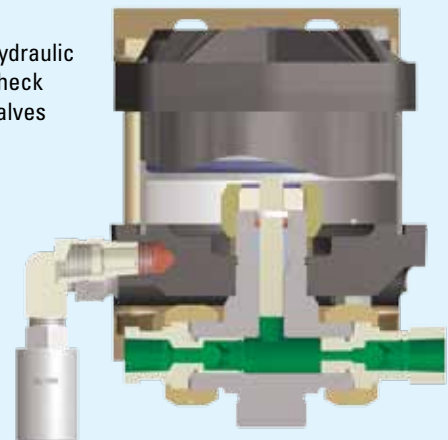

3. Drive Cycling Valve

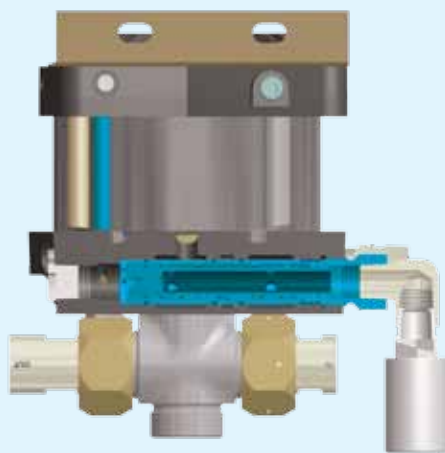

4. Hydraulic Seal

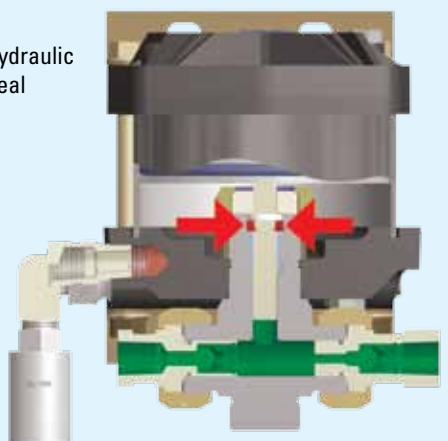

## Anatomy of a Pneumatic Driven Pump

### 1. Drive Section

The piston, complete with “O” ring seal, operates in an epoxy filled, fiberglass wound barrel, the diameter of which is constant throughout a given series of pumps. Drive media forces the piston down on the compression stroke and raises it on the suction stroke (M series have a spring return). The piston is pre-lubricated during assembly and therefore no air line lubricator is necessary.

### 2. Hydraulic Section/Check Valves

The drive piston is linked and connected to the hydraulic plunger/piston in the hydraulic section. Outlet flow and pressure are determined by the area of the hydraulic piston head, its nominal ratio with the drive piston head, and drive pressure. On the down stroke, liquid in the hydraulic section is forced under compression through the outlet check valve. Fresh liquid is induced via the inlet check valve on the return stroke. These check valves control the flow of liquid through the hydraulic section. They are spring-loaded and have a very low cracking pressure, allowing maximum opening on the induction stroke. The pressure of hydraulic fluid on the down stroke closes the inlet check valve and acts against the spring to open the outlet check valve.

### 3. Drive Cycling Valve

This is a pilot-operated, unbalanced, lightweight spool, which directs drive pressure, first to the top of the drive piston, and then to the underside to reciprocate the piston (cycle). It actuates via pilot valves at the top and the bottom of the stroke, which causes the unbalanced spool to shift and reciprocate the piston.

### 4. Hydraulic Seal/Check Valves

This is one of the few wear parts. Its function is to allow the hydraulic piston to reciprocate without passing fluid into the drive section. The liquid, its pressure and its temperature determine seal specification. A distance piece can be incorporated between drive and hydraulic sections for complete contamination-free operation on most Haskel pumps.



# WETTED MATERIALS OF CONSTRUCTION AND SERVICES

	MODEL	SERVICES (refer to pg. 17)	WETTED MATERIALS		NON METALLICS
			PUMP SECTION	PLUNGERS	
.33 hp	M	1	Cad plated steel, Aluminum & SS	416 SS	Urethane, PTFE, Buna
	MS	1, 2	All SS	316 SS	UHMWPE, PTFE, Buna
	29723	1, 2, 3, 5, 6	Separation - All SS	Hard Chrome Plated 15.5PH SS + Dichronite	UHMWPE, PTFE, Ryton
	MDSTV	1, 2, 3, 4, 5, 6	Stainless Steel and Aluminum	303 Stainless Steel	Viton, PTFE
	MDTV	1, 2, 3, 5, 6	Stainless Steel and Aluminum	303 Stainless Steel	Viton, PTFE
	MCPV	1, 2, 3, 4, 5, 6	All SS	15-5 PH Stainless Steel	PTFE, Viton, Ryton
.75hp	4B-14 thru -37	1,2	Aluminum	Aluminum(Hard coated)	UHMWPE, Buna
	4B-55 thru -150	1,2	303 SS	440 C. SS	UHMWPE, Buna
1.5 hp	AW	1	Nickel Plated Steel & SS	440C SS	Urethane, Buna N, PTFE
	ASF	1,2	All SS	440C SS	UHMWPE, Buna, PTFE, Ryton
	DF	1,3,5	Separation - Nickel Plated Steel & SS	440C SS	UHMWPE, Viton, PTFE, Ryton
	DSF	1,2,3,5,6	Separation - All SS	440C SS Hard Chrome Plated	UHMWPE, Viton, PTFE, Ryton
	HF	1	Nickel Plated Steel & SS	Stellite 15-5PH SS	UHMWPE, Buna N
	HSF	1,2	All SS	Stellite 15-5PH SS	UHMWPE, Buna N
	DSHF	1,2,5,6	Separation - All SS	Stellite 15-5PH SS	UHMWPE, Buna N
	ATV	1,2	Aluminum, Bronze & SS	15.5PH SS	PTFE, Viton
	DTV	1,2,5	Separation - Aluminum, Bronze & SS	15.5PH SS	PTFE, Viton
	DSTV-1.5	1,2,3,4,5,6	Separation - All SS	17.4PH SS	PTFE, Viton
	DSTV	1,2,3,4,5	Separation - All SS	440C SS Hard Chrome Plated	PTFE, Viton
	DHF	1,2	SS, 300 Series and 17-4	Stellite 6B	PTFE, Buna, UHMWPE
DTN	1,2,5	Stainless Steel, Aluminum	300 Series SS	Neopreen, PTFE	
2 thru 3 hp	AW	1	Nickel Plated Steel & SS	440C SS	Urethane, Buna N, PTFE
	AFD	1	Nickel Plated Steel & SS	416 SS	UHMWPE, Buna, PTFE, Ryton
	DFD	1, 3, 5	Nickel Plated Steel & SS	416 SS	UHMWPE, Viton, PTFE, Ryton
	ASFD	1, 2	All SS	15.5PH SS	UHMWPE, Viton, PTFE, Ryton
	ASF	1, 2	All SS	440C SS	UHMWPE, Viton, PTFE, Ryton
	DSFD	1, 2, 3, 5, 6	Separation - All SS	15.5PH SS	UHMWPE, Viton, PTFE, Ryton
	DF	1, 3, 5	Separation - Nickel Plated Steel & SS	440C SS	UHMWPE, Viton, PTFE, Ryton
	DSF	1, 2, 3, 5, 6	Separation - All SS	440C SS Hard chrome plated	UHMWPE, Viton, PTFE, Ryton
	HF	1	Nickel Plated Steel & SS	Stellite 15-5PH SS*	UHMWPE, Buna N
	HSF	1, 2	All SS	Stellite 15-5PH SS*	UHMWPE, Buna N
	DSHF	1, 2, 5, 6	Separation - All SS	Stellite 15-5PH SS*	UHMWPE, Buna N
	DXHF	1, 5	Separation - Nickel Plated Steel & SS	Stellite 15-5PH SS*	UHMWPE, Buna N
	DSXHF	1, 2, 5, 6	Separation - All SS	Stellite 15-5PH SS	UHMWPE, Buna N
	DSXHW	1, 2	Separation - All SS	Stellite 15-5PH SS	Urethane, PTFE
	DSTV-1.5	1, 2, 3, 4, 5, 6	Separation - All SS	17.4PH SS	PTFE, Viton
DSTV	1, 2, 3, 4, 5	Separation - All SS	440C SS Hard chrome plated	PTFE, Viton	
DHF	1, 2	SS, 300 Series and 17-4	Stellite 6B	PTFE, Buna, UHMWPE	
*Except -202 ratio is chrome plated 440 SS					
6 hp	GW	1	Nickel Plated Steel, SS & Bronze	Hard chrome plated 15.5PH SS	Urethane, Buna N, PTFE
	GSF	1, 2	All SS & Bronze	Hard chrome plated 15.5PH SS	UHMWPE, Viton, PTFE, Ryton
	DGF	1, 3, 5	Separation- Nickel Plated Steel & SS	Hard chrome plated 15.5PH SS	UHMWPE, Viton, PTFE, Ryton
	DGSF	1, 2, 3, 5, 6	Separation- All SS & Bronze	Hard chrome plated 15.5PH SS	UHMWPE, Viton, PTFE, Ryton
	DGSTV	1, 2, 3, 4, 5	Separation- All SS & Bronze	Hard chrome plated 15.5PH SS	Viton, PTFE, Ryton
	GWD	1	Nickel Plated Steel & SS	15.5PH SS Hard chrome plate optional	Urethane, Buna N, PTFE
	GSFD	1, 2	All SS & Bronze	15.5PH SS Hard chrome plate optional	UHMWPE, Buena N, PTFE, Ryton
	DGFD	1, 3, 5	Separation- Nickel Plated Steel & SS	15.5PH SS hard chrome plate optional	UHMWPE, Viton, PTFE, Ryton
	DGSFD	1, 2, 3, 4, 5, 6	Separation- All SS & Bronze	15.5PH SS Hard chrome plate optional	UHMWPE, Viton, PTFE, Ryton
	DGSTVD	1, 2, 3, 4, 5	Separation- All SS & Bronze	17.4PH SS Hard chrome plate optional	PTFE, Viton
8 hp	8FD	1	Nickel Plated Steel, SS & Bronze	Hard chrome plated 15.5PH SS	UHMWPE, Viton, PTFE, Ryton
	8SFD	1, 2	All SS & Bronze*	Hard chrome plated 15.5PH SS	UHMWPE, Viton, PTFE, Ryton
	8DFD	1, 3, 5	Nickel Plated Steel & SS	15.5PH SS	UHMWPE, Viton, PTFE, Ryton
	8DSFD	1, 2, 3, 5, 6	Separation- All SS & Bronze	15.5PH SS Hard chrome	UHMWPE, Viton, PTFE, Ryton
	8DSTVD	1, 2, 3, 4, 5, 6	Separation- All SS & Bronze	15.5PH SS Hard chrome	PTFE, Viton
	8HSFD	1, 2	All SS & Bronze*	17.4PH SS	UHMWPE, Viton, PTFE, Ryton
	8DSTVD	1, 2, 3, 5, 6	All SS & Bronze*	15-5 PH SS Hard chrome	Viton, PTFE
	8SFD2	1,2,6	All SS & Bronze*	15-5 PH SS Hard chrome	PTFE, Viton, UHMWPE
10 hp	D14STD-125	1, 2, 3, 4, 5A	All SS & Bronze	Hard chrome plated 440C SS	PTFE, Viton
	D14STD-315	1, 2, 3, 4, 5A	All SS & Bronze	Hard chrome plated 440C SS	PTFE, Viton
	D14SFD-125	1, 2, 3, 5A, 6	All SS & Bronze	Tungston Carbide Coated 15.5PH SS	UHMWPE, Viton, PTFE, Ryton
	D14SFD-315	1, 2, 3, 5A, 6	All SS & Bronze	Tungston Carbide Coated 15.5PH SS	UHMWPE, Viton, PTFE, Ryton



Typical Performance using 100 psi (7 bar) Air drive

Outlet Pressure		Outlet Flow		Outlet Pressure		Outlet Flow	
psi	bar	cu in/min	l/min	psi	bar	cu in/min	l/min
225	15.5	500	8.20	415	29	249	4.09
300	21	350	5.70	600	41	160	2.6
700	48	200	3.28	1125	78	100	1.64
1500	103	90	1.48	2000	138	48.9	0.8
1700	117	70	1.15	3100	214	39.6	0.65
2450	169	tbd	tbd	4500	310	tbd	tbd
3000	207	40	0.64	6000	414	19	0.31
7500	517	20	0.33	10000	690	8.5	0.14
5000	345	18	0.30	10000	690	14	0.23
5000	345	18	0.30	10000	690	14	0.23
7500	517	15	0.24	15000	1034	12	0.2
700	48	400	6.55	1450	100	61	1.00
1000	69	270	4.42	2000	138	120	2.00
1250	86	230	3.77	2500	172	61	1.00
1500	103	200	3.28	3000	207	62	1.00
1750	121	170	2.78	3500	241	82	1.33
2000	138	110	1.80	5000	345	66	1.08
2500	172	87	1.42	7500	517	37	0.60
5000	345	57	0.93	10000	690	26	0.43
7500	517	37	0.60	15000	1034	7	0.11
50	3	5000	81.9	150	10	1000	16.4
100	7	1953	32	400	28	750	12.3
400	28	1000	16.4	990	68	500	8.19
750	52	598	9.8	1600	110	200	3.28
1000	69	403	6.6	2500	172	195	3.2
2000	138	350	4.1	3600	248	98	1.6
3000	207	152	2.5	6200	427	50	0.82
4000	276	100	1.64	10000	690	24.4	0.4
7000	483	59.7	0.98	15000	1034	29.9	0.49
7000	483	59.7	0.98	15000	1034	29.9	0.49
7500	517	39.6	0.65	24000	1655	9.8	0.16
15000	1034	29.9	0.49	27000	1862	20.1	0.33
36000	2483	14.6	0.24	45000	3103	9.2	0.15
200	14	1953	32	800	28	750	12.3
400	28	799	13.1	2100	145	200	3.28
700	48	500	8.2	3000	207	152	2.50
1900	131	299	4.9	5000	345	98	1.60
2000	138	226	3.7	7500	517	50	0.82
4000	276	122	2.0	12000	828	40.2	0.66
7000	483	91.5	1.5	20000	1379	20.1	0.33
10000	690	45.2	0.7	30000	2069	15.2	0.25
10000	690	34.8	0.6	40000	2759	15.2	0.25
15000	1034	24.4	0.4	50000	3448	12.2	0.2
15000	1034	19.5	0.32	60000	4138	4.9	0.08
15000	1034	15.9	0.26	70000	4828	5.5	0.09
16000	1103	9.2	0.15	90000	6207	3.1	0.05
1000	69	348	5.7	5500	379	152	2.5
500	34	1520	24.9	1000	69	380	6.22
750	52	1030	16.9	1500	103	260	4.26
1000	69	662	10.9	2500	172	162	2.66
1500	1034	465	7.6	3500	248	100	1.64
3000	138	248	4.1	6000	414	56	0.92
5000	345	151	2.5	10000	690	41	0.67
7500	517	103	2.0	15000	1034	27	0.44
10000	690	63	1.0	20000	1379	47	0.77
200	14	5004	82	1200	83	1454	24
1000	69	1770	29	3500	241	600	9.8
2000	138	976	16	5500	379	397	6.5
2000	138	573	9.4	10000	690	195	3.2
1000	69	2400	39.3	2500	172	280	4.6
2000	138	1420	23.2	4000	276	200	3.27
3000	207	880	14.4	6000	414	310	5.08
5000	345	555	9.1	10000	690	163	2.67
10000	690	270	4.4	20000	1379	144	2.36
2500	172	1230	20.1	4000	276	675	11
4000	276	850	13.9	5000	345	800	13.1
10000	690	315	5.2	18500	1276	140	2.3
8000	552	488	8.0	12000	828	195	3.2
15000	1034	238	3.9	30000	2069	79.3	1.3

## Pump Selection Information

All Haskel pumps are identified by letters coding the type of pump, followed by a number indicating the practical working ratio of the drive area to the hydraulic plunger area. These letters are explained in the chart below.

### Pump Model Letter Coding

<b>M</b>	.875" stroke .33 hp miniature pump series
<b>S</b>	Stainless steel hydraulic piston and body
<b>29723</b>	.33 hp Chemical Pump
<b>D (Prefix)</b>	Pump incorporates a Distance Piece
<b>D (Suffix)</b>	Double Acting pump
<b>4B</b>	1" stroke .75 hp pump series (bottom inlet only)
<b>A</b>	2" stroke 1.5 + 2 hp pump series
<b>H</b>	2" stroke 1.5 + 2 hp High Pressure pump series
<b>-C</b>	Filter, regulator with gauge and shut-off/speed control valve
<b>XH</b>	2" stroke 1.5 + 2 hp Extreme High Pressure pump series
<b>G</b>	4.5" stroke 6 hp pump series
<b>8</b>	4.5" stroke 8 hp pump or booster series
<b>14</b>	4" stroke 10 hp pump series
<b>W</b>	Polyurethane U-cup dynamic seal
<b>F</b>	UHMWPE (Ultra-high Molecular Weight Polyethylene Dynamic Seal
<b>T</b>	Reinforced Teflon® dynamic seal
<b>V</b>	Viton® o-ring static seal
<b>-B</b>	Bottom inlet
<b>-CP</b>	Chemical Pump



## Guidelines for Continuous Duty Applications for Maximizing Seal Life Performance

Pump Series	Maximum Cycles per Minute
0.3 hp	325 cpm
0.75 hp	225 cpm
1.5, 2.0 and 2.2 hp (Single and Double Drive Piston)	80 cpm
2.0 hp (Triple Drive Piston)	60 cpm
3.0 hp	80 cpm
6.0 hp	60 cpm
8.0 hp	50 cpm
10.0 hp	40 cpm

## .33 hp (.25 kW) M Series Pump Models



### Key Features

- Choice of 6 models, 9 ratios, 27 possible combinations
- Flows to 2 gpm (7.5 l/min)
- Choice of wetted materials
- Single air head
- Drive pressure 25 to 125 psi (1.8 to 9 bar)
- Pressures to 25,000 psi (1724 bar)
- All Hydraulic fluids, water (plain or DI), solvents, mild chemicals, liquefied gases

### Optional Modifications

Number	Description
-HP	Hand pump attachment (with handle). Provides manual operation of pump for precision pressure control or use without air power.
26082	Handle only.
26220-2	With handle.
26220-3	Without handle.
	Kits for converting existing units.
-V	Manual release with relief valve. For M and MS pumps only. Provides high pressure needle valve with internal adjustable safety relief downstream of pump outlet checks. Tank return is 1/8" NPT in pump body.
26063-3	Dead Man valve. 1/4" NPT port.
26064-3	Combination air regulator/filter with gauge. 1/4" NPT port.
26065-3	Speed control valve. 1/4" NPT port.
26065-3 plus 26064-3	-C air controls installed on pump. 1/4" NPT port.
28320	Manifold mount inlet port. Provides O-ring boss in aluminum block to enable mounting on side of tank below oil level. Modification applies to M-21 through M-188 only.
28590	Palm or foot start/stop button drive. Spring loaded shut.
28700-1	Air OP release valve.
28926	Remote start/stop control. Provides 1/8" NPT bleed signal port for single line remote control.
29002	Viton air drive.
29697	Single stroke from remote air pulse. Useful for metering applications. One stroke per air pulse signal; eliminates automatic cycling. 1/8" NPT signal port.
51331	EPR seals for liquid section for 29723-XX ratio pumps.
51788	Piped exhaust – standard. Provides connection ports for drive and pilot exhausts. Enables under tank top mounting and/or natural gas drive.
51794	Piped exhaust – sour gas. With hand pump (HP).
51794-2	Piped exhaust – sour gas. Without hand pump (HP).
51804	Muffler (for use with piped exhaust modifications below). 1/4" NPT male port.

Model	Nominal Ratio	Maximum Working Pressure <small>Consult chart on page 6 for more information regarding continuous/intermittent pressures.</small>	Displacement per Cycle
M, MDSTV	-5	625 psi (43 bar)	.83 cu in (13.6 ml)
M, MS	-7	900 psi (62 bar)	.6 cu in (9.8 ml)
	-12	1500 psi (103 bar)	.36 cu in (5.9 ml)
M, MS, MCPV, 29723	-21	2600 psi (179 bar)	.2 cu in (3.3 ml)
	-36	4500 psi (310 bar)	.12 cu in (2.0 ml)
	-50	6500 psi (448 bar)	.088 cu in (1.4 ml)
	-71	8800 psi (607 bar)	.06 cu in (1.0 ml)
M, MS	-110	13500 psi (931 bar)	.039 cu in (0.6 ml)
	-188	15000 psi (1034 bar)	.023 cu in (.4 ml)
MCPV, 29723	-110	10,000 psi (688 bar)	.039 cu in (0.6 ml)
	-188		.023 cu in (.4 ml)
MS	-220	25000 psi (1723 bar)	.021 cu in (.34 ml)

*For service codes, see page 17.*

*For weights and dimensions, see page 18.*

Number	Description
51809	Normally open air operated release with relief valve. Provides highest release flow capacity. Will hold full pump psi piloted from drive air. Vents are not threaded. Ref. drawing 56643 for tank top mounting parts.
51809-1	Normally closed air operated release with relief valve. Used to hold hydraulic jacks. Will release up to 11000 psi (using 100 psi air). Vents are not threaded. Ref. drawing 56643 for tank top mounting parts. Not available in 188:1 ratio.
51810	Safety relief valve. Relief is upstream of outlet check. Vent hole 1/16 NPT M or MS series -21 through 188.
51811	External air pilot. Provides 1/8" NPT port for external air to pilot for remote start/stop.
52340	Solid air cap.
52950	Electric stroke counter provision. Micro switch (BZE6-2RQ) mounted on upper cap trips with each cycle.
53175	Level II cleaning.
53304	High pressure outlet port. Fits 1/4" O.D. high pressure threaded and coned tube.
53784	Piped exhaust (drive only). For field conversion of any .33 HP pump. Provides 1/4" NPT exhaust port.
53935	Low temperature drive. Enables operation down to 5°F. Some sacrifice of seal life at normal temperature. M or MS series.
54179	Stroke adjuster (includes 29697 above). Useful for metering applications. Knurled knob with vertical scale on pump cap.
57905	No return spring. Provides improved fill on suction stroke pumping liquefied gases by utilizing the inlet pressure. Only available on M and MS series.
59888	Cycle timer installed.
80103	Noise reduction kit fitted.
80348	SAE outlet for M-pumps, 3/8" SAE, 6500 psi (448 bar) max.
81499	EPR Seals for M and MS series for Liquid Section.
82367	SS trim for 1/2 hp drive
82500	ATEX Modification (Available on MS & 29723 but not M series).
85630	Conversion kit, new style exhaust muffler.
86337	Extended life air drive.

## .75 hp (.56 kW) Pump Models



### Key Features

- One model available in 9 ratios
- Output pressures to 15,000 psi (1034 bar)
- Flows to 1.5 gpm (5.7 l/min)
- Choice of wetted materials
- Single air head
- Drive pressure 3 psi to 100 psi (.2 to 7 bar)

### Optional Modifications

Number	Description	Number	Description
-C	Air drive controls.	59888	Cycle timer installed.
56564	Extreme cycling service. Not recommended for long stall periods.	80637	SAE outlet fitting for ratio 37 to 100, 1/4" SAE, 6500 psi (448 bar) max.
56594	External air pilot. Provides 1/8" NPT port for external air to pilot for remote start/stop operation.	81575	Changes the "F" seal to a "W" seal. Recommend for use with water.
57639	Low drive air pressure. Allows user to regulate drive air to as low as 3 psi (.2 bar).	82104	Viton air drive.
57960	Single acting drive. Used for pumping liquefied gases under pressure.	82500	ATEX modification.
58475	1/8" NPT port on drive for recycle valve connection.	86337	Extended life air drive.
59354	Noise reduction kit fitted.		

Model	Nominal Ratio	Maximum Working Pressure	Displacement per Cycle
		Consult chart on page 6 for more information regarding continuous/intermittent pressures.	
4B	-14	1500 psi (103 bar)	.9 cu in (14.8 ml)
	-21	2300 psi (159 bar)	.6 cu in (9.8 ml)
	-25	2700 psi (186 bar)	.5 cu in (8.2 ml)
	-30	3200 psi (221 bar)	.43 cu in (7.1 ml)
	-37	3800 psi (262 bar)	.35 cu in (5.7 ml)
	-55	6000 psi (414 bar)	.22 cu in (3.6 ml)
	-75	7800 psi (538 bar)	.17 cu in (2.8 ml)
	-100	10600 psi (731 bar)	.13 cu in (2.1 ml)
	-150	15000 psi (1034 bar)	.088 cu in (1.4 ml)

For service codes, see page 17.

For weights and dimensions, see page 19.



## 1.5 hp (1.12 kW) Pump Models



### Key Features

- Choice of 11 models, 13 ratios, 50 possible combinations
- Output pressures to 50,000 psi (3448 bar)
- Flows to 22 gpm (83.0 l/min)
- Choice of wetted materials
- Single air head
- Drive pressure 3 to 150 psi (.2 to 10 bar)

### Optional Modifications

Number	Description
-C	Air controls (filter, regulator, gauge, shut-off). ½" NPT.
-CP	Air controls with precision regulator. ½" NPT.
-CO	Air controls with recycle button. ½" NPT.
-CPO	Air controls with precision regulator and recycle button. ½" NPT.
-B	Bottom Inlet (designate "B" before ratio dash number, "BR" on -B10, -B15, -B22 and -B32) 1.5 hp and 2 hp pumps (not applicable to high output, chemical, 2.2 hp, or AWD series pumps).
-W	Additional upper foot bracket.
16821	Low air pressure control feature. For operating at air pressures as low as 3 to 4 psi (.2 to .3 bar). Includes 28881 modification.
16831	Low temperature modification. For special sealing in air drive for operating temperatures from as low as -20°F up to normal +120°F.
16834	Exhaust adapter. With back pressure balance piston.
17860	Electrical stroke counter provision. Includes BZE6-2RQ microswitch.
25721	Mechanical stroke counter, installed (6 digit).
27964	Interconnecting inlet-outlet tubing. ½" female for 4:1 ratio series pumps (ATV-4 or DTV-4).
28000	Threaded vent (or purge) ports on standard distance piece. Except 1.5:1 ratio.
28003	Test port. Provides access port in pump's body between inlet and outlet check valves for 1.5 hp and 2 hp pumps. -10 ratio or higher, single acting.
28881	Air pilot modification. ½" NPT. Allows remote start/stop of pump.
29376	Three-way cycling spool. For 1.5 hp and 2 hp single acting pumps, for use with CO <sub>2</sub>
29702	Single stroke modification.
29806	Double distance piece. For 1.5 hp and 2 hp pumps only, except 1.5:1 ratio.

Model	Nominal Ratio	Maximum Working Pressure <small>Consult chart on page 6 for more information regarding continuous/intermittent pressures.</small>	Displacement per Cycle
DSTV <sup>(1)</sup>	-1.5	160 psi (11 bar)	31.9 cu in (513.0 ml)
ATV, DTV <sup>(1) (2)</sup> DTN <sup>(1)</sup>	-4	1200 psi (83 bar)	20.0 cu in (328.0 ml)
AW, ASF, DF, DSF, DSTV	-B10	1600 psi (110 bar)	4 cu in (66.4 ml)
	-B15	2400 psi (165 bar)	2.7 cu in (44.3 ml)
	-25	4000 psi (276 bar)	1.6 cu in (26.6 ml)
	-35	5700 psi (393 bar)	1.2 cu in (19 ml)
	-60	9800 psi (676 bar)	.7 cu in (11 ml)
ATV	-8	850 psi (59 bar)	20 cu in (328.0 ml)
AW, ASF, DF, DSF, DSTV	-100	16500 psi (1138 bar)	.4 cu in (6.7 ml)
	-150	20000 psi (1375 bar)	.28 cu in (4.5 ml)
HF, HSF, DSHF	-151	25000 psi (1724 bar)	.28 cu in (4.5 ml)
	-225	37000 psi (2551 bar)	.18 cu in (3.0 ml)
	-300	50000 psi (3448 bar)	.14 cu in (2.3 ml)
HF	-450	45000 psi (3403 bar)	.09 cu in (1.5 ml)

(1) These series are "Lift" pumps and maximum outlet pressure is (air drive x pump ratio) + inlet pressure

(2) DTV has poppet checks

*For service codes, see page 17.*

*For weights and dimensions, see page 20.*

Number	Description
51050	Extreme service cycling modification. Not recommended for long stall periods.
51056	Exhaust/pilot vent combination.
51331	EPR (Ethylene propylene) static seals in wetted section. Applies to distance piece pumps only.
51345	Sour gas drive provision to N.A.C.E. specifications. 1.5 hp to 2.2 hp distance piece pumps only, single air head and double air head.
52788	Viton seals air drive.
53925	Severe Arctic low temperature service. -25, -35, -60, -100, -150, -151, -225, -300, -450 ratios.
54885	Rotate pump body 90° from standard.
54935	SS trim for 5/3 air drive.
55305	Tube ports. ⅝" SAE inlet and outlet. For 1.5 hp to 2 hp pumps. 15 pump minimum.
55516	Polyurethane ("W") seal. For F or TV series pumps, except high output models.
55630	Stainless steel (AISI-316) distance piece. For 1.5 hp to 2 hp pumps.
59353	Noise reduction kit fitted. Not available on AFD, DFD, ASFD or DSFD.
81453	¾ HP outlet fitting.
81453-2	¼ HP inlet fitting.
82460	HNBR seals in air drive section.
82500	ATEX modification (not available on AW or DSXHW pumps).
82958	Medium pressure outlet port.
86337	Extended life air drive.

## 1.5 hp (1.12 kW) High Output Flow Pumps

Available in a choice of 4 models, these high output, low ratio pumps are capable of pressures to 1200 psi (82 bar) and flow rates of up to 22 gpm (83 l/min). These are "lift" pumps whereby the outlet pressure equals the air drive x the pump ratio plus the inlet pressure.

Model DSTV-1.5 has a maximum air drive of 150 psi (10 bar) and is capable of pressures up to 160 psi (11 bar). The model ATV, DTN-4 and DTV-4 work on a maximum air drive of 150 psi (10 bar) and have a maximum intermittent pressure rating of 1200 psi (83 bar). A noise reduction modification is available for applications where noise level is an issue.

## Distance Piece (Separation)

Pumps with prefix "D" in the model number have aluminum distance piece between the air drive and pump section (except DSTV-1.5). Vent holes can be threaded 1/2" NPT female at extra cost. Specify modification number 28000. Horizontal mounting is recommended for non-exchange of contaminants.

## Mounting Brackets

All series mounting brackets have 7/16" holes (slots) for 3/8" bolts. Upper mounting brackets are not furnished as standard on single air head non-distance piece units.

### Dimensional Data

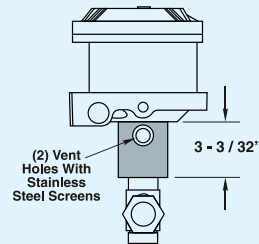

### Mounting Brackets

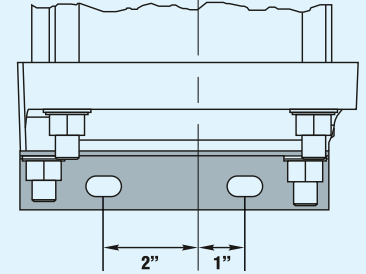

## Optional Pump Inlets for Tank Mounting

To specify ratios -10, -15, -22 or -32, add "BR" between the model number and the ratio, e.g. AW-BR10.

Inlet externally threaded 1 1/4" NPT male  
Internally threaded 1" NPT female

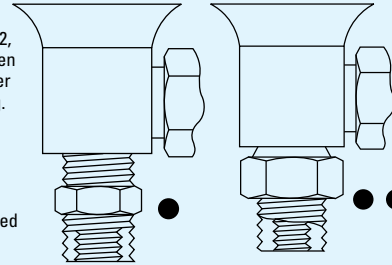

To specify ratios -25 through -903, add "B" between the model number and the ratio, e.g. AW-B25.

Inlet on the bottom and externally threaded 1" NPT male  
Internally threaded 1/2" NPT female

Drive inlet and exhaust are 1/2" NPT female. Drive inlet also includes a 1/2" NPT male x 1/2" NPSM female (straight pipe thread) swivel adapter (connecting male nipple should include 30° inside bevel for proper fit).



## 2 & 2.2 hp (1.49 & 1.64 kW) Pump Models



### Key Features

- Choice of 16 models, 13 ratios, 46 possible combinations
- Output pressures to 100000 psi (7000 bar)
- Flows to 5 gpm (15 l/min)
- Choice of wetted materials
- Double and triple air heads
- Drive pressure 3 to 100 psi (.2 to 7 bar)

When using high pressure ratio pumps the reliability of the XH models (-452 through -1373) will be improved with an air driven supercharge pump, not only to simplify priming but to reduce fatigue stresses. The higher the supercharge, the better the results. Also install a relief valve to protect the lower pressure pump from potential back pressure. Supercharging of the -1373 model is recommended. This approach will ensure a reasonable life for the seals and other wear components.

Model	Nominal Ratio	Maximum Working Pressure <small>Consult chart on page 6 for more information regarding continuous/intermittent pressures.</small>	Displacement per Cycle
AW, ASF, DF, DSF, DSTV	-B22	3200 psi (221 bar)	4 cu in (66.4 ml)
	-B32	4800 psi (331 bar)	2.7 cu in (44.3 ml)
	-52	8000 psi (552 bar)	1.6 cu in (26.6 ml)
	-72	11000 psi (758 bar)	1.2 cu in (19 ml)
	-122	19000 psi (1310 bar)	.7 cu in (11 ml)
HF, HSF, DHF, DSHF	-202	33000 psi (2275 bar)	.4 cu in (6.7 ml)
	-302	50000 psi (3448 bar)	.28 cu in (4.5 ml)
DXHF, DSXHF	-452	70000 psi (4827 bar)	.18 cu in (3.0 ml)
	-602	75000 psi (5171 bar)	.14 cu in (2.3 ml)
DXHF, DSXHF	-683	70000 psi (4827 bar)	.18 cu in (3.0 ml)
	-903	75000 psi (5171 bar)	.14 cu in (2.3 ml)
DSXHW	-1373	100000 psi (6895 bar)	.09 cu in (1.4 ml)
AFD, DSFD, DFD, ASFD	-B60	6500 psi (448 bar)	1.3 cu in (22 ml)

*For service codes, see page 17.*

*For weights and dimensions, see page 20.*

## 3 hp (2.24 kW) Pump Models



### Key Features

- One model available in 8 ratios
- Output pressures to 33000 psi (2275 bar)
- Flow rates to 8 gpm (30 l/min)
- Single air head
- Drive pressure 3 to 150 psi (.2 to 10 bar)

Model	Nominal Ratio	Maximum Working Pressure <small>Consult chart on page 6 for more information regarding continuous/intermittent pressures.</small>	Displacement per Cycle
ASFD	10	1600 psi (110 bar)	8.1 cu in (132.8 ml)
	15	2400 psi (165 bar)	5.4 cu in (88.6 ml)
	25	4000 psi (276 bar)	3.3 cu in (53.2 ml)
	35	5700 psi (393 bar)	2.3 cu in (38 ml)
	60	9800 psi (676 bar)	1.3 cu in (22 ml)
	100	16500 psi (1138 bar)	.8 cu in (13.4 ml)
	150	20000 psi (1379 bar)	.6 cu in (9 ml)
	202	33000 psi (2275 bar)	.8 cu in (13.4 ml)

*For service codes, see page 17.*

*For weights and dimensions, see page 21.*

## Optional Modifications (for 2 hp, 2.2 hp and 3 hp pump models)

Number	Description
-C	Air controls (filter, regulator, gauge, shut-off. ½" NPT.
-CP	Air controls with precision regulator. ½" NPT.
-CO	Air controls with recycle button. ½" NPT.
-CPO	Air controls with precision regulator and recycle button. ½" NPT.
-B	Bottom Inlet (designate "B" before ratio dash number, "BR" on -B10, -B15, -B22 and -B32) 1.5 hp and 2 hp pumps (not applicable to high output, chemical, 2.2 hp, or AWD series pumps)
16821	Assures reliable drive operation with pressures low as 3 psi as long as 20 psi or more is provided to the separate ½" NPT port.
16831	Low temperature modification. For special sealing in air drive for operating temperatures from as low as -20°F up to normal +120°F.
16834	Exhaust adapter. With back pressure balance piston.
17860	Electrical stroke counter provision. Includes BZE6-2RQ microswitch.
25721	Mechanical stroke counter. Installed (6 digit).
27964	Interconnecting inlet-outlet tubing. ½" female for 4:1 ratio series pumps (ATV-4 or DTV-4).
28000	Threaded vent (or purge) ports on standard distance piece. Except 1.5:1 ratio and 3 hp pump.
28003	Test port. Provides access port in pump's body between inlet and outlet check valves for 1.5 hp and 2 hp pumps, -10 ratio or higher, single acting.
28881	External air pilot. Provides ⅛" NPT port for external air to pilot for remote start/stop operation.
29376	Three-way cycling spool. For 1.5 hp and 2 hp single acting pumps.
29702	Single stroke modification. Except 3 hp pump.
29806	Double distance piece. For 1.5 hp and 2 hp pumps only, except 1.5:1 ratio.
51050	Extreme service cycling modification. Not recommended for long stall periods.

Number	Description
51056	Exhaust/pilot vent combiner.
51331	EPR (Ethylene propylene) static seals in wetted section. Applies to distance piece pumps only.
51345	Sour gas drive provision to N.A.C.E. specifications. 1.5 hp to 2.2 hp distance piece pumps only, single air head and double air head.
52788	Viton seals. Air drive only – 1.5 hp to 2.2 hp pumps only.
53925	Severe Arctic low temperature service. -25, -35, -60, -100, -150, -151, -225, -300, -450 ratios except 3 hp pump.
54885	Rotate pump body 90° from standard. Except 3 hp pump.
54935	SS trim for 5/3 air drive.
55191	Mounting ring kit for AWD series.
55192	3/4 NPT inlet port installed on AWD series (in place of threaded port).
55193	Extra foot bracket installed.
55305	Tube ports. ⅝" SAE inlet and outlet – for 1.5 hp to 2 hp pumps, 15 pump minimum.
55465	Ceramic Plunger -60 Ratio.
55516	Polyurethane "W" seal in "F" series pumps-except high output models.
55630	Stainless steel (SS-316) distance piece – for 1.5 thru 2 hp pumps.
59353	Noise reduction kit fitted. Not available on AFD, DFD, ASFD or DSFD.
59888	Cycle timer installed.
81453	3/8 HP outlet fitting.
81453-2	1/4 HP inlet fitting.
82460	HNBR Seals in air drive section.
82500	ATEX modification (not available on AW or DSXHW pumps).
86337	Extended life air drive.

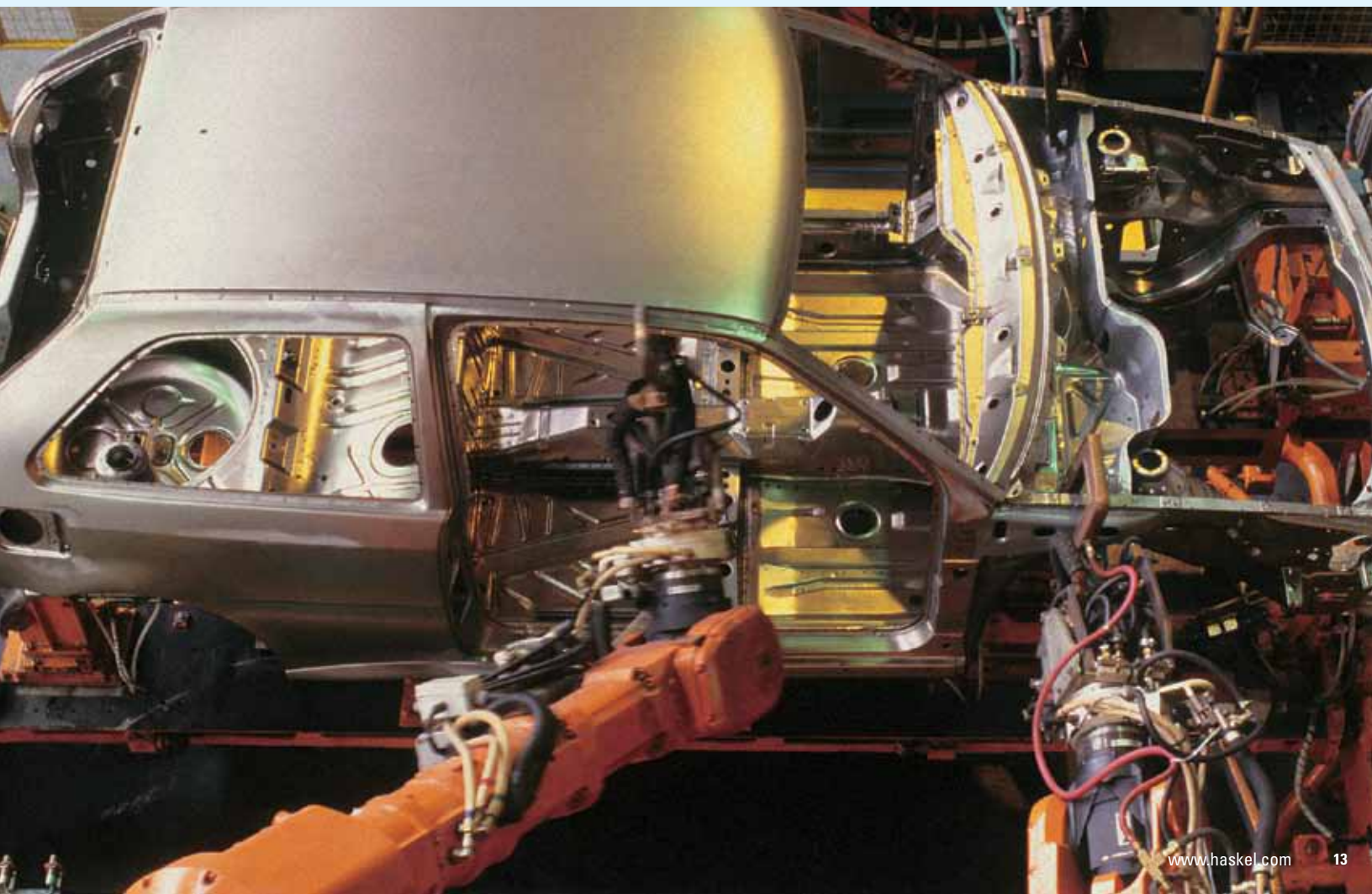

## 6 hp (4.47 kW) Pump Models



### Key Features

- Choice of 10 models, 4 ratios, 20 possible combinations
- Output pressures to 10,000 psi (690 bar)
- Flow rates to 21 gpm (80 l/min)
- Choice of wetted materials
- Single air head – double acting
- Drive pressure 3 to 125 psi (.2 to 9 bar)
- All hydraulic fluids, water (plain or DI), solvents

Model	Nominal Ratio	Maximum Working Pressure <small>Consult chart on page 6 for more information regarding continuous/intermittent pressures.</small>	Displacement per Cycle
<b>GW, GSF, DGFD<sup>(1)</sup>, DGSFD<sup>(1)</sup>, DGSTVD<sup>(1)</sup></b>	-12	4000 psi (276 bar)	15.9 cu in (260 ml)
<b>GW, GSF, DGF, DGSF, DGSTV</b>	-35	4375 psi (302 bar)	6.0 cu in (98 ml)
	-60	7500 psi (517 bar)	3.5 cu in (57 ml)
	-100	10000 psi (690 bar)	2.1 cu in (34.5 ml)

(1) Double Acting "Lift" Pumps

*For service codes, see page 17.*

*For weights and dimensions, see page 22.*

Incorporating 10 models, this heavy duty range of double acting pumps provide pressures up to 10,000 psi (690 bar) and flow rates up to 4 gpm (15 l/min).

Designed to operate with air drive pressures between 40 and 125 psi (2.8 and 9 bar). For drive pressures 3 to 40 psi (.2 to 2.8 bar), order 51875-1 mod.

## 8 hp (5.97 kW) Pump Models



### Key Features

- Choice of 9 models, 8 ratios, 9 possible combinations
- Pressures to 30,000 psi (2068 bar)
- Flow rates to 11.5 gpm (44 l/min)
- All hydraulic fluids, water (plain or DI), solvents, liquefied gases
- Choice of wetted materials
- Single air head – double acting
- Drive pressure 3 to 125 psi (.2 to 9 bar)

Model	Nominal Ratio	Maximum Working Pressure <small>Consult chart on page 6 for more information regarding continuous/intermittent pressures.</small>	Displacement per Cycle
<b>8SFD, 8DFD, 8DSFD, 8DSTVD, 8FD</b>	-25 <sup>(1)</sup>	4000 psi (276 bar)	14 cu in (229 ml)
<b>8SFD</b>	-40	6000 psi (408 bar)	9 cu in (145.3 ml)
	-65	10000 psi (690 bar)	5.4 cu in (88.2 ml)
<b>8DSFD</b>	-100 <sup>(1)</sup>	10000 psi (690 bar)	3.5 cu in (57.5 ml)
<b>8SFD2<sup>(1)</sup></b>	-55	7200 psi (496 bar)	14 cu in (229 ml)
	-88	10000 psi (786 bar)	8.83 cu in (144 ml)
	-224	29000 psi (1724 bar)	3.5 cu in (57 ml)
<b>8HSFD</b>	-225 <sup>(1)</sup>	25000 psi (1724 bar)	1.6 cu in (25.5 ml)

(1) Double Acting "Lift" Pumps

*For service codes, see page 17.*

*For weights and dimensions, see page 23.*

## 10 hp (7.46 kW) Pump Models



### Key Features

- Choice of 4 models, 4 ratios, 4 possible combinations
- Pressures to 36000 psi (2500 bar)
- Flow rates to 3 gpm (11 l/min)
- Drive pressure 3 to 125 psi (.2 to 9 bar)
- All hydraulic fluids, water (plain or DI), solvents, liquefied gases
- Choice of wetted materials

Model	Nominal Ratio	Maximum Working Pressure	Displacement per Cycle
		<small>Consult chart on page 6 for more information regarding continuous/intermittent pressures.</small>	
D14STD	125 <sup>(1)</sup>	16000 psi (1103 bar)	8.8 cu in (144.2 ml) 3.5 cu in (57.4 ml)
	315 <sup>(1)</sup>	36000 psi (2482 bar)	
D14SFD	125 <sup>(1)</sup>	16000 psi (1103 bar)	8.8 cu in (144.2 ml) 3.5 cu in (57.4 ml)
	315 <sup>(1)</sup>	36000 psi (2482 bar)	

(1) Double Acting "Lift" Pumps

*For service codes, see page 17.*

*For weights and dimensions, see page 23.*

Incorporating two basic models, this heavy duty range of double acting pumps provide pressures up to 36000 psi (2482 bar) and output flow rate up to 3 gpm (11 l/min).

Operating from a maximum air drive pressure of 125 psi (9 bar), these pumps are designed for medium to high pressure service with minimum maintenance.

These large, slow speed pumps approach a seal life as high as 5 times that of many smaller pumps and this advantage becomes ever greater in heavy duty service involving water, or other liquids with negligible lubricity.

### Optional Modifications (for 6 hp, 8 hp and 10 hp pump)

Number	Description
C	Air controls.
17860	Electrical stroke counter provision (includes BZE6-2RQ micro switch).
25721	Mechanical stroke counter installed (6 digit).
29077	Interconnecting tubing – 6 hp and 8 hp pumps, double ended.
29077-1	Interconnecting tubing – 6 hp and 8 hp pumps, double ended low ratio pumps.
29078	Same as 29077, 29077-1 double ended w/distance piece.
29078-1	Same as 29077, 29077-1 double ended w/distance piece low ratio pumps.
29079	Interconnecting tubing – 10 hp pumps.
29125	External pilot modification – for 6 hp thru 10 hp pumps.
29702-2	Single stroke.
51875-1	Low air pressure control – for 6 hp thru 10 hp pumps.
54030	Sour gas air drive provision to NACE spec. 6 hp distance piece pumps only.

Number	Description
54312	Extreme service cycling modification – for 6 hp thru 10 hp pumps.
54936	Exhaust/pilot vent combiner.
55330	Interconnecting tubing 8DSFD-100 low pressure inlet.
55330-1	Interconnecting tubing 8DSFD-100 high pressure inlet.
55366	Interconnecting tubing 8DSFD-225.
57002	Viton seals – air drive only – 6 hp.
57944	Viton seals – air drive only – 8 hp.
59888	Cycle timer installed.
82500	ATEX modification available for 6 hp only, not available on 8 hp or 14 hp drive, nor on GW, GSF, DGSF, GSFD, or DGSFD models.
86337	Extended life air drive.



## Power System Specialists

World safety standards and quality demands are rising. Component manufacturers are required to provide test certification and product quality assurance which can only be determined using the types of systems which Haskel can provide. Typically, we have built systems for production and field testing the proof, leak, and burst aspects of hoses, cylinders, and valves.

These systems can be portable, mobile, or static test rigs. We also offer a range of standard pressure packs used for power jacking, clamping, and other applications where reliable power is needed.

## Selecting Your Accessories

Haskel can either provide accessories separately or supply them fitted to form a complete package suited to your application. Additionally, Haskel can fit customer nominated accessories. Our accessories catalog is available and our technical support team is always ready to advise you on the most suitable choice of accessories for your application.

- Air pilot switches
- Air pilot valves
- Regulating relief valves
- Directional control and release valves
- Hydraulic accumulators, gas receivers and storage cylinders
- High pressure valves, fittings and tubing
- Plenum chambers
- Port adapters
- Pressure regulators
- Gauge snubbers
- Filters
- Stainless steel check valves
- Intensifiers with integral checks for cycling
- Capillary type gauge snubbers

*Please ask for your copy of our latest accessories brochure.*



## Quality and After-Sale Service

Haskel meets the requirements of international quality assurance ISO 9001. Build quality is matched by an innovative design and problem solving ability which stems from years of years of experience. Our representatives around the world are carefully chosen and trained to help you arrive at a correct product choice, and to offer a maintenance and parts service that is second to none.



## Liquids Compatible with Haskel Pumps

To assist in easier pump selection, we have classified various popular liquids in groups and assigned to each group a service code. These service code numbers are featured in the chart to the right and are designated for each pump series. Seals and other wetted materials can be supplied to suit your preferred liquid. For advice, please contact our technical services personnel at 818-843-4000.

## Services

### Service Codes

- 1** Petroleum-based oils, kerosene, water with 5% soluble oil.
- 2** Plain water, diesel fuel.
- 3** Most phosphate ester-based fire-resistant hydraulic fluids, e.g. Pydraul, Lindol, Cellulube, Fyrquel, and Houghtosafe 1120 and petroleum-based solvents compatible with UHMWPE (Ultra-high Molecular Weight Polyethylene) dynamic seals and Viton static seals.
- 4** Petroleum-based solvents, e.g. aromatic hydrocarbons (benzene, toluene, xylene, hylene, etc.); chlorinated solvents (trichlorethylene, carbon tetrachloride, chlorobenzine, etc.); mercaptans, Dowtherm A, fluoronated solvents (fluorobenzene, fluorochlorethylene, etc.); Dowtherm E, plus all of Group 3 and some mildly corrosive acids compatible with wetted materials. See note 5A for service with methyl-ethyl-ketone, methyl acetone, diacetone, alcohol and freon 22.
- 5** Skydrol and Aerosafe hydraulic fluid; acetone and some alcohols (ethyl, methyl, and isopropyl).  
**5A.** Also suitable for these fluids if Viton static seals are replaced with EPR; specify modification number 51331 (no extra charge); e.g., 51331-MDTV-5. Most phosphate ester-based fluids solidify at approximately 30000 psi.
- 6** Deionized water; demineralized water.

**Note: Dynamic seal life with non-lubricating fluids will understandably be less than with lubricating types.**

## Operating Temperatures

### Drive Section

-4° (25°F) to +65°C (150°F) (low temperature seals are available for Arctic operation).

### Liquid Section

For reasonable seal life, high temperature should be limited to 54° C (130° F), for F and W seal models, 135° C (275° F) for T and TV models (with distance piece).

		Services					
hp	Model	1	2	3	4	5	6
.33	M	•					
	MS	•	•				•
	MDTV	•	•	•		•	•
	MDSTV	•	•	•	•	•	•
	MCPV	•	•	•	•	•	•
	29723	•	•	•		•	•
.75	4B -14 to -37	•	•				•
	4B -55 to -150	•	•				•
1.5 2 2.2	AW	•					
	ASF	•	•				•
	DF	•		•		•	
	DSF	•	•	•		•	•
	HF	•	•				
	HSF	•	•				•
	DHF	•	•			•	
	DSHF	•	•			•	•
	DSTV	•	•	•	•	•	•
	ATV	•	•	•			•
	DTV	•	•			•	•
	DSTV -1.5	•	•	•	•	•	•
	AFD	•		•			
	DFD	•		•		•	
	ASFD	•	•				•
DSFD	•	•	•		•	•	
DXHF	•	•			•		
DSXHF	•	•			•	•	
DSXHW	•	•				•	
3	ASFD	•	•				•
6	GW	•					•
	GSF	•	•				•
	DGF	•		•		•	
	DGSF	•	•	•		•	•
	DGSTV	•	•	•	•	•	•
	GWD	•					
	GSFD	•	•	•		•	•
	DGFD	•		•		•	
	DGSFD	•	•	•	•	•	•
	DGSTVD	•	•	•	•	•	•
8	8FD	•					•
	8SFD	•	•	•	•	•	•
	8SFD2	•	•	•	•	•	•
	8DFD	•					
	8DSFD	•	•	•		•	•
	8DSTVD	•	•	•		•	•
	8HSFD	•	•	•	•	•	•
10	D14STD -125	•	•	•	•	•	•
	D14STD -315	•	•	•	•	•	•
	D14SFD -125	•	•	•		•	•
	D14SFD -315	•	•	•		•	•

# Weights and Dimensions

## .33 hp (.25 kW) M Series Pump Models

NB. Plan view of M-Pump is common to all M-Series pumps.

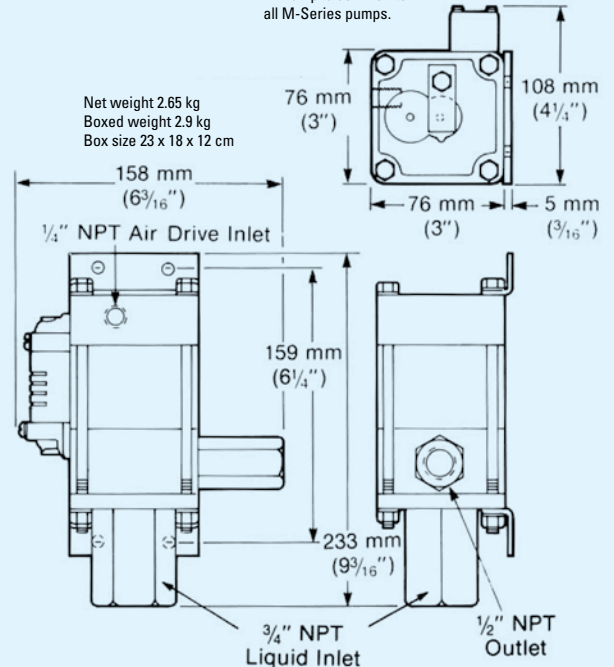

**M-7, M-12**  
approx. weight 9 lbs (4 kg)

**MS-7, MS-12**  
approx. weight 9 lbs (4 kg)

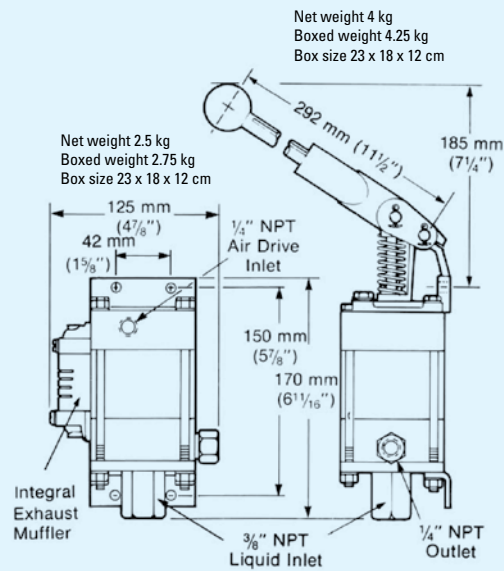

**MS-21, MS-36, MS-71, MS-110, MS-188, approx. weight 6 lbs (2.7 kg)**

**M-21, M-36, M-71, M-110, M-188 approx. weight 6 lbs (2.7 kg)**

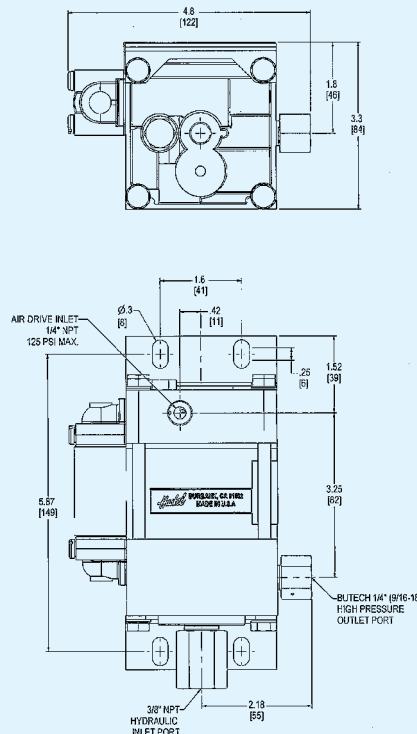

**MS-220 approx. weight 6 lbs (2.7 kg)**

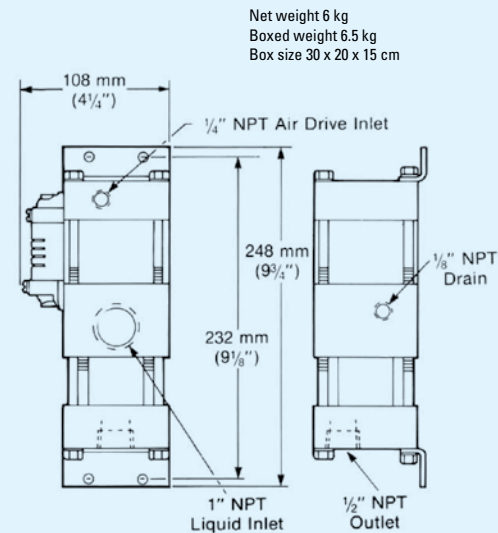

**M-5 approx. weight 9 lbs (4 kg)**

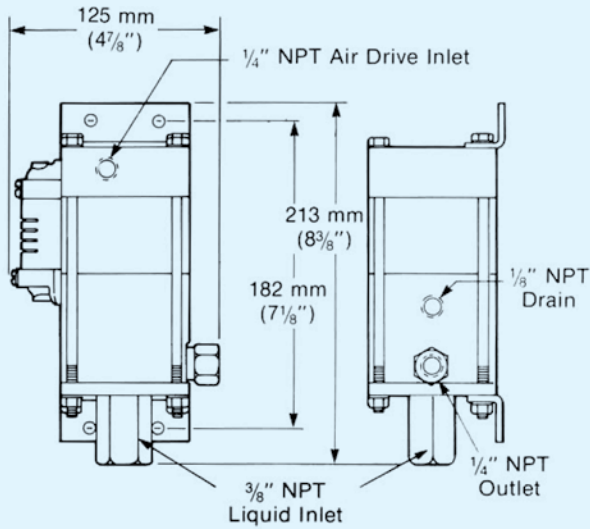

29723-21, 29723-36, 29723-71, 29723-110  
approx. weight 6.5 lbs (3 kg)

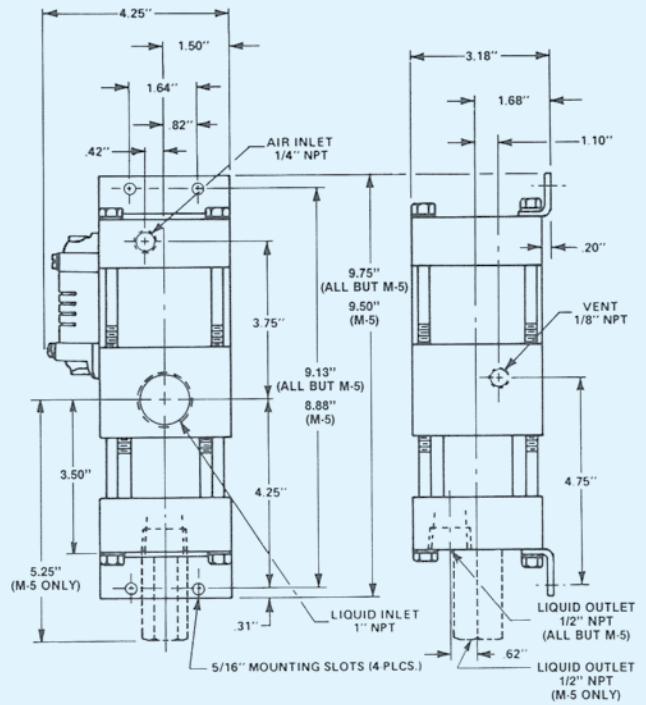

MDSTV-5, MDTV  
Approx weight 15 1/2 lbs (7 kg)

.75 hp (.56 kW) Pump Models

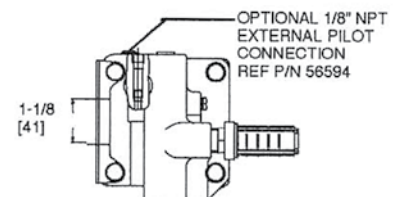
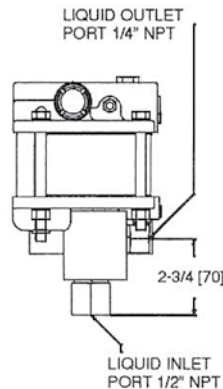
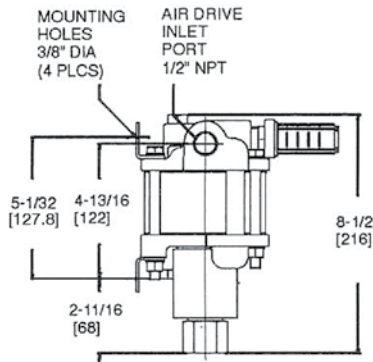
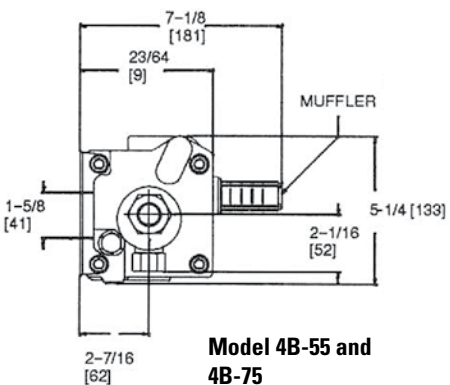
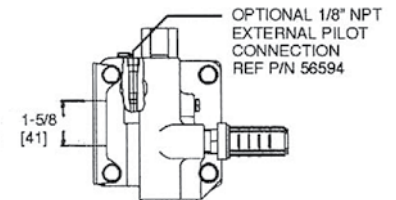
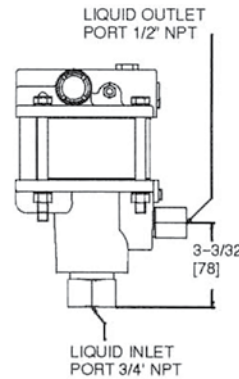
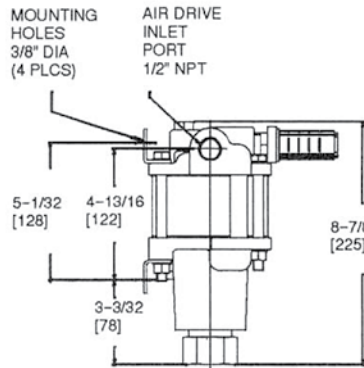
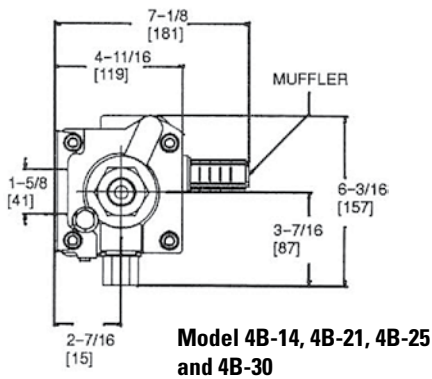

# 1.5 hp, 2 & 2.2 hp (1.12, 1.49 & 1.64 kW) Pump Models

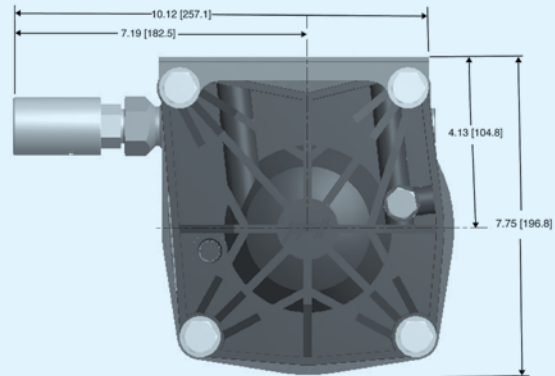
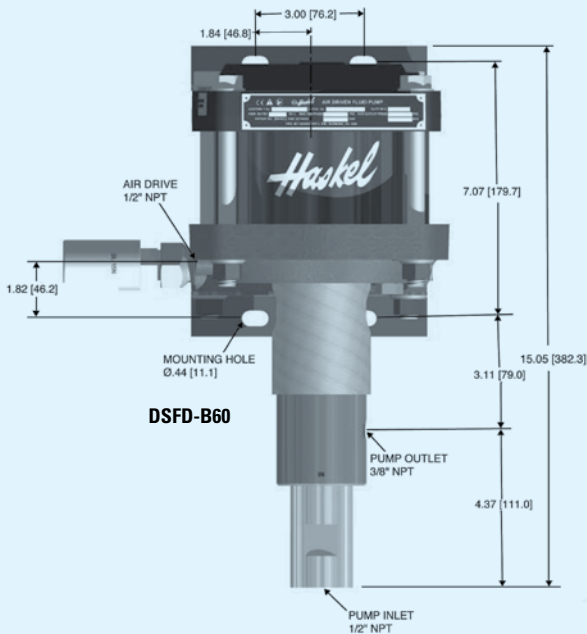

Net weight 18 kg  
Boxed weight 20 kg  
Box size 68 x 42 x 50 cm

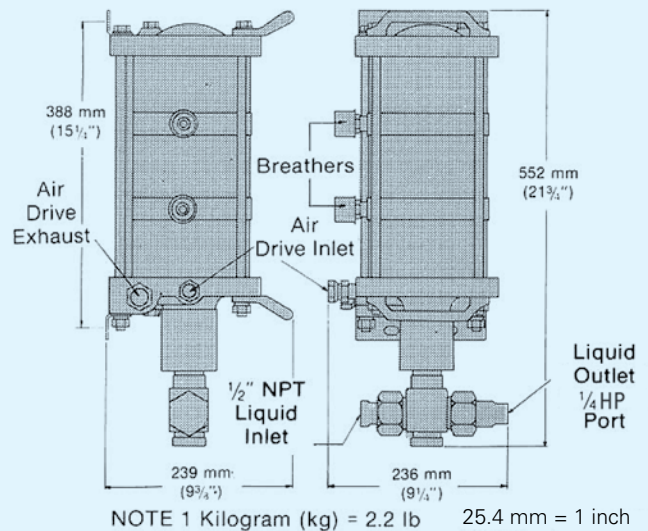
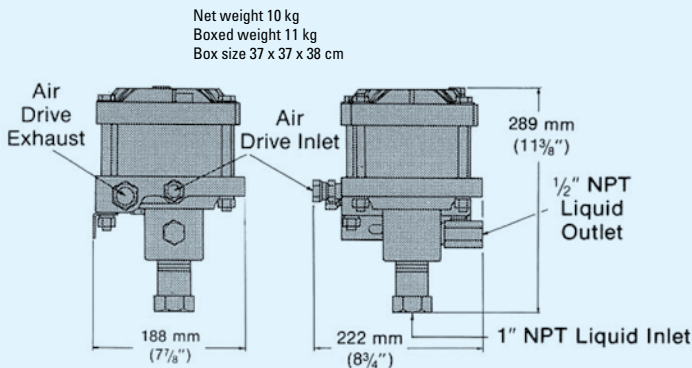

2 hp high ratio pumps;  
-683 and -903 ratios

1.5 and 2 hp low ratio pumps;  
-B10 and -B15 ratios

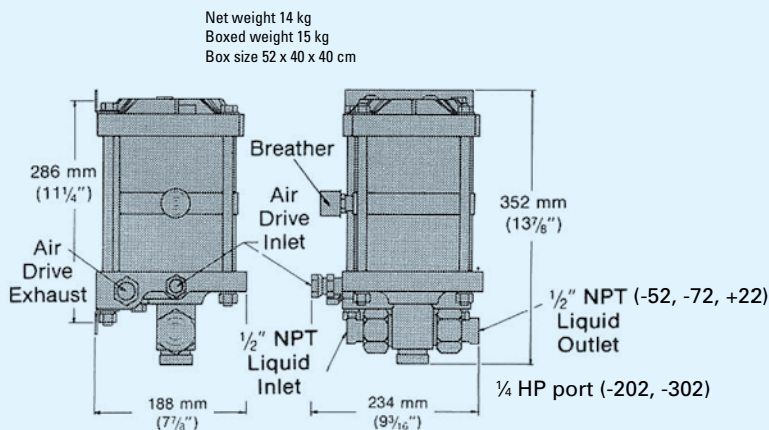

1.5 and 2 hp medium ratio pumps;  
-52, -72, -122, -202 and -302 ratios

DSXHW - 1373 (PART NUMBER 29660)

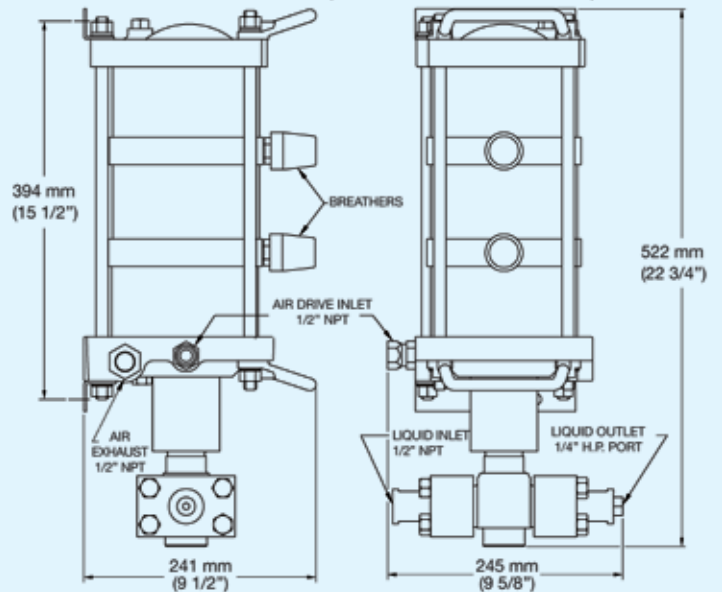

2 hp (1.49 & 1.64 kW) Pump Models;  
-1373 ratio

## .75 hp (.56 kW) Pump Models (cont.)

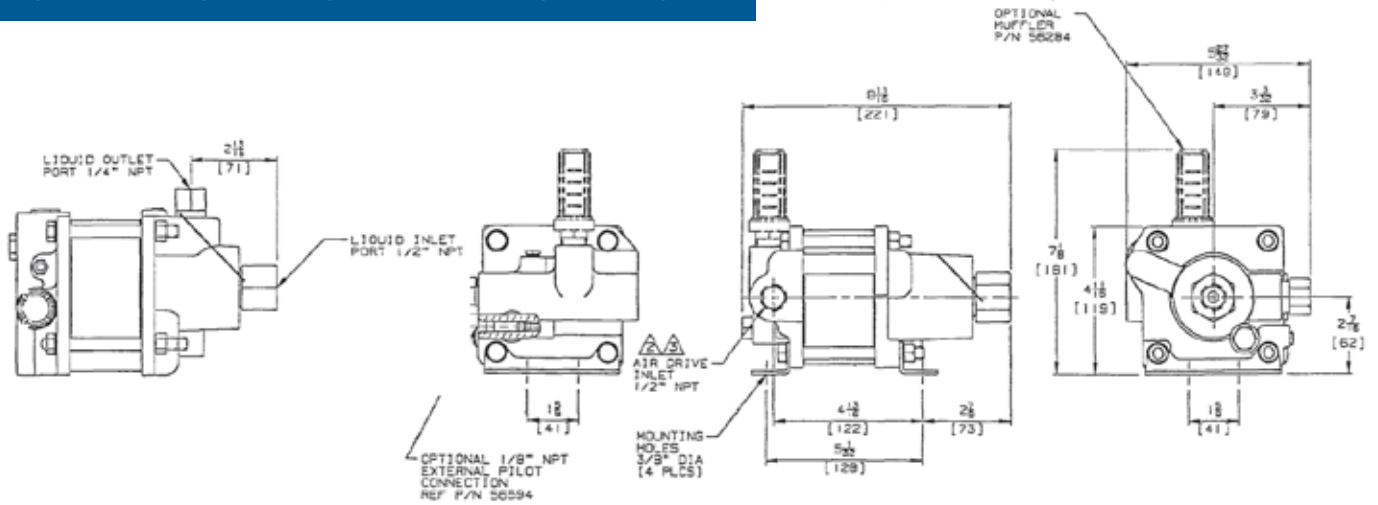

**Model 4B-37**  
approx. weight 10 lbs (4.5 kg)

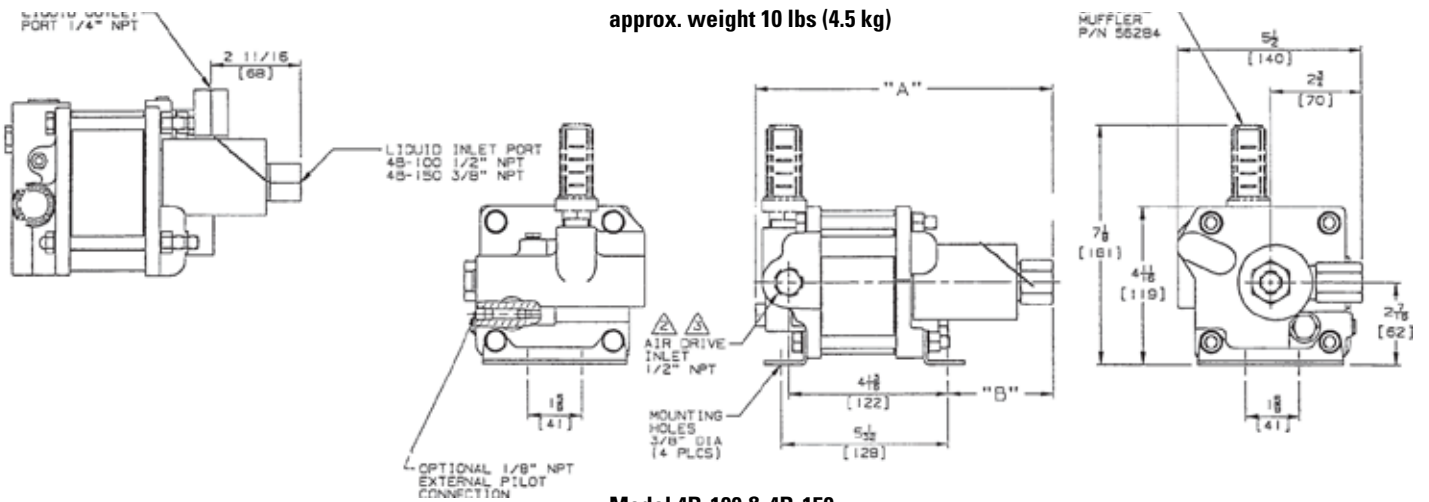

**Model 4B-100 & 4B-150**  
approx. weight 11 lbs (5 kg)

## 1.5 hp, 2&2.2 hp (1.12, 1.49 & 1.64 kW) Pump Models

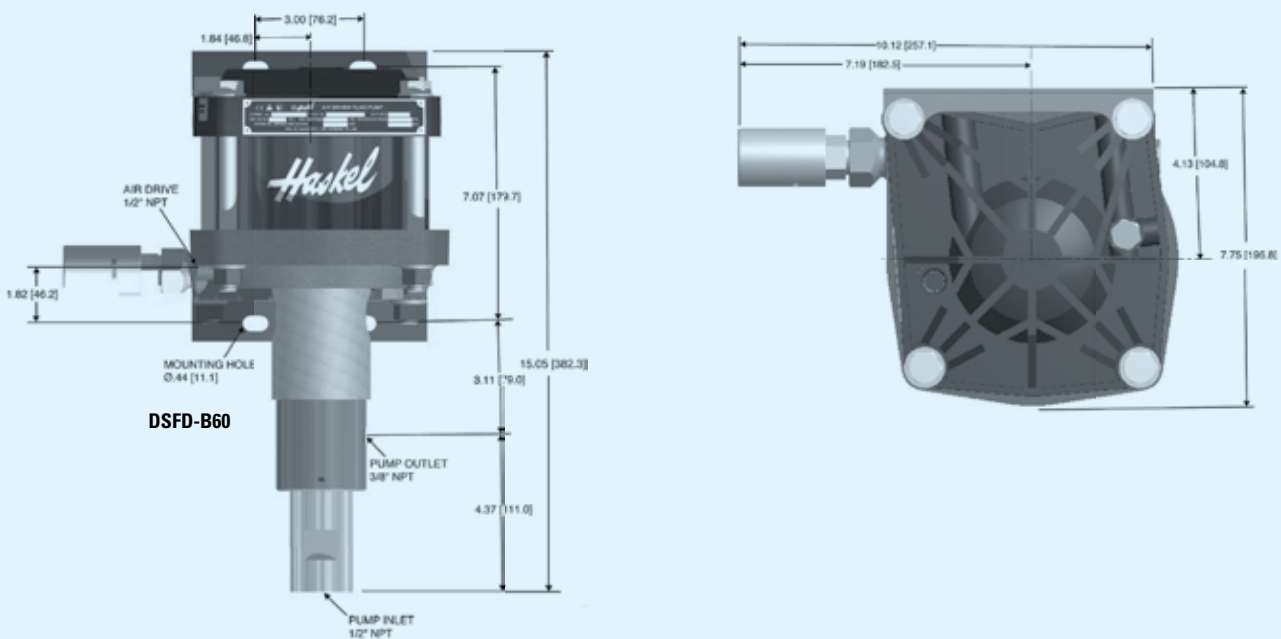

# 1.5 hp, 2 & 2.2 hp (1.12, 1.49 & 1.64 kW) Pump Models (cont.)

Net weight 10 kg  
Boxed weight 11 kg  
Box size 37 x 37 x 38 cm

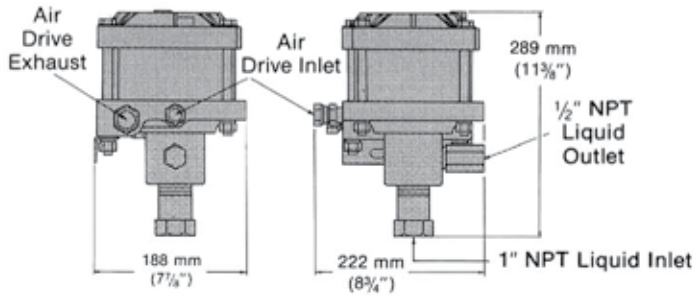

**1.5 and 2 hp low ratio pumps;  
-B10 and -B15 ratios**

Net weight 14 kg  
Boxed weight 15 kg  
Box size 52 x 40 x 40 cm

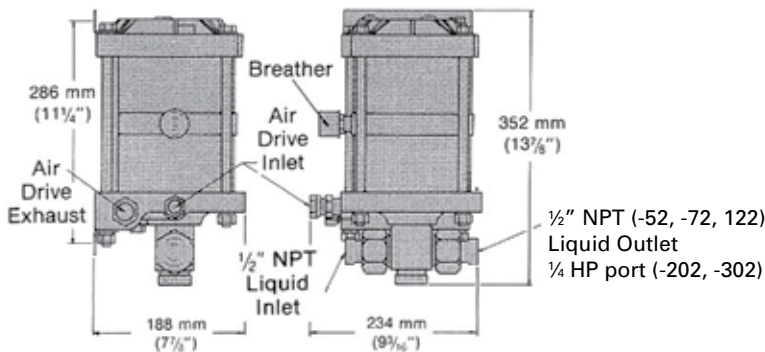

**1.5 and 2 hp medium ratio pumps;  
-52, -72, -122, -202 and -302 ratios**

Net weight 10 kg  
Boxed weight 11 kg  
Box size 45 x 37 x 44 cm

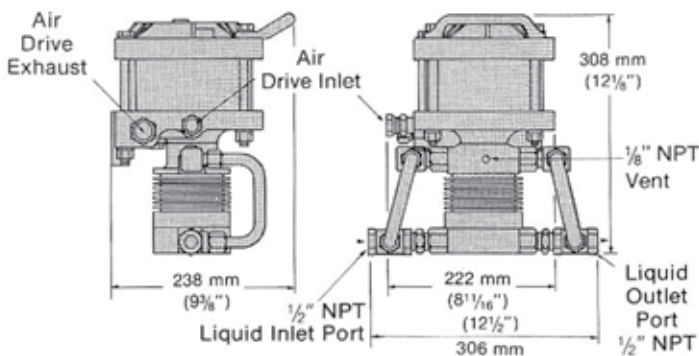

**ATV-4 pumps; double acting, high output**

Note: For model DTV-4, add distance piece dimension from page 11.  
Interconnecting inlet and outlet port tubing shown.

Net weight 18 kg  
Boxed weight 20 kg  
Box size 68 x 42 x 50 cm

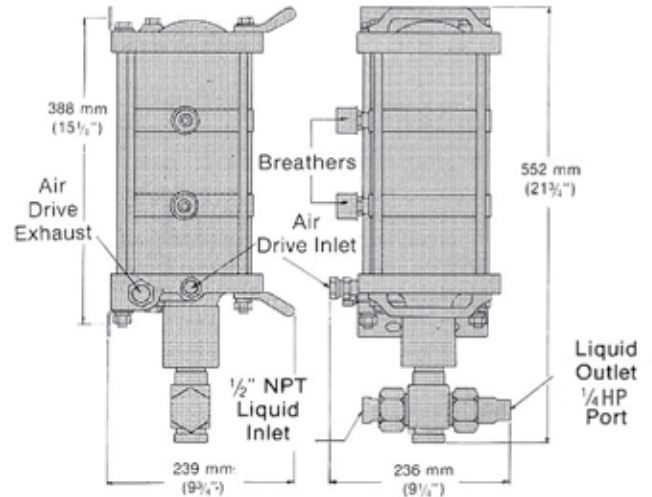

NOTE 1 Kilogram (kg) = 2.2 lb    25.4 mm = 1 inch

**2 hp high ratio pumps;  
-683 and -903 ratios**

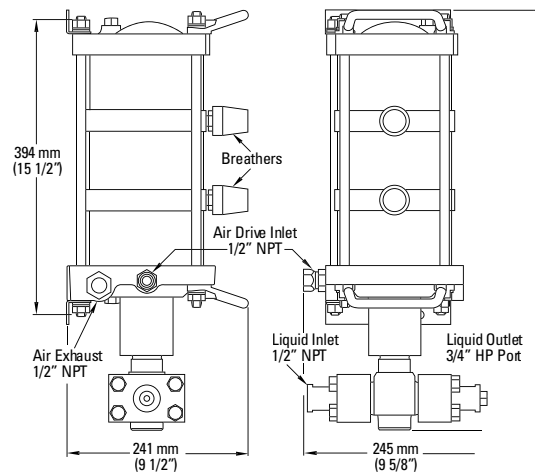

**2 hp (1.49 & 1.64 kW) pump models;  
-1373 ratio**

Net weight 18 kg  
Boxed weight 19 kg  
Box size 45 x 37 x 44 cm

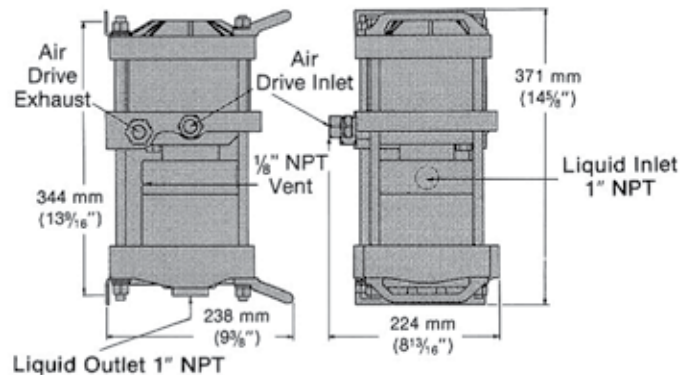

**DSTV-1.5 pump; single acting, high output**

Net weight 9.5 kg  
 Boxed weight 10 kg  
 Box size 25 x 26 x 22 cm

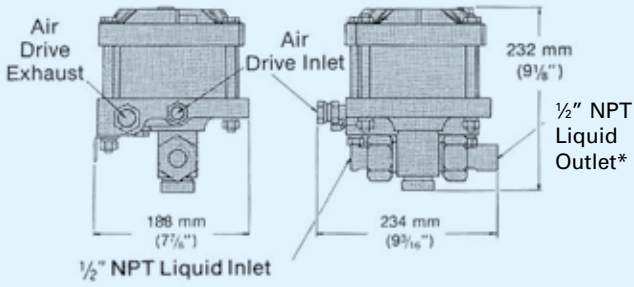

**1.5 and 2 hp medium and high ratios; -25 through -150, -151\*, -225\*, -300\* and -450\* ratios**  
 \*1/4" Super Pressure Outlet Port

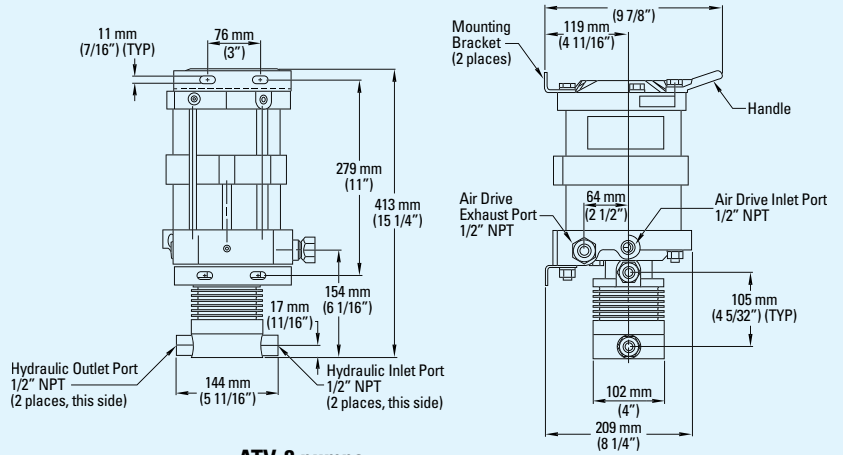

**ATV-8 pumps**

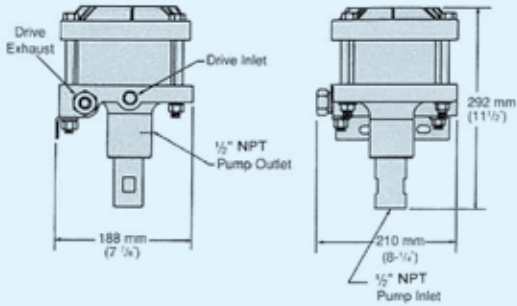

**AFD or ASFD, -B60, -B100 pumps; double acting, high output**

**3 hp (2.24 kW) Pump Models**

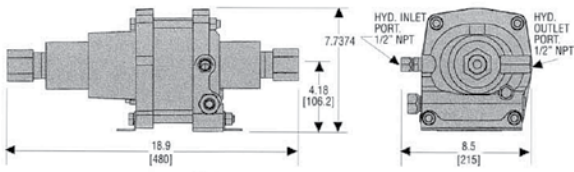

**ASFD-15**

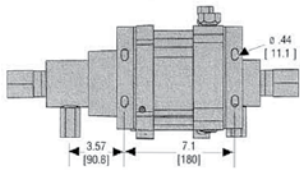

**ASFD-10**

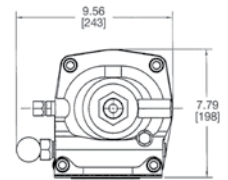
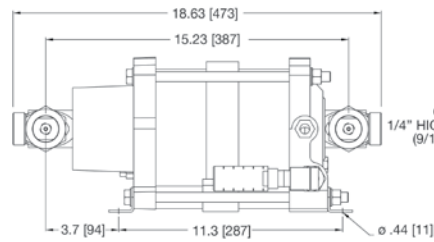
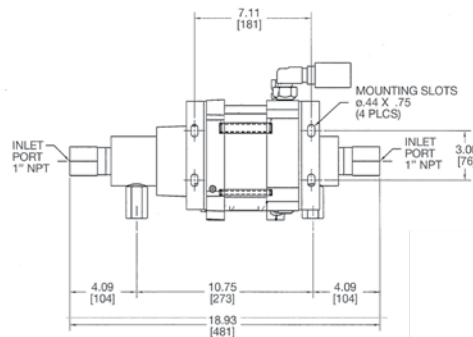
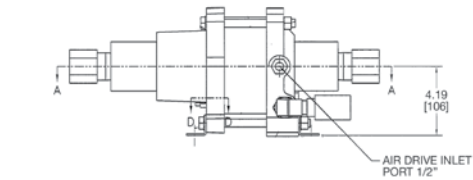
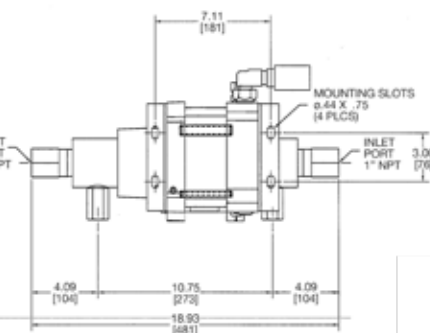
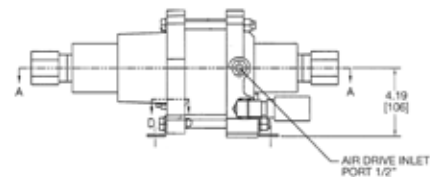

**ASFD-25  
 ASFD-35,  
 ASFD-60  
 ASFD-100 } 3/8" med.  
 ASFD-150 } pressure**



**ASFD-202**

# 6 hp (4.47 kW) Pump Models

Net weight 31 lbs (14 kg)  
 Boxed weight 35 lbs (16 kg)  
 Box size 52 x 39 x 39 cm

All models have 2 off 1/4" NPT air exhaust ports and 1 off 3/4" NPT air drive inlet ports.

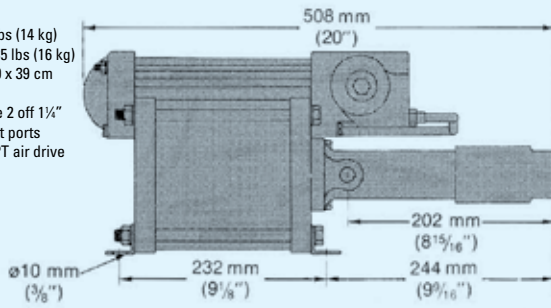

**Models GW, GSF nominal ratio 35, 60 100:1**

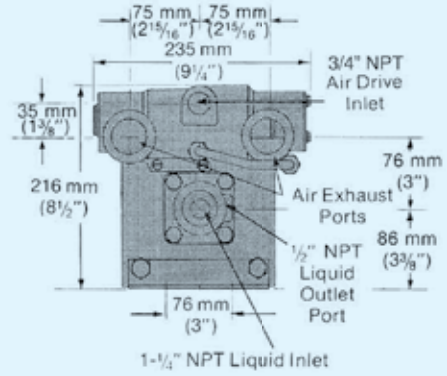

Net weight 41 lbs (18.5 kg)  
 Boxed weight 48 (22 kg)  
 Box size 66 x 41 x 49 cm

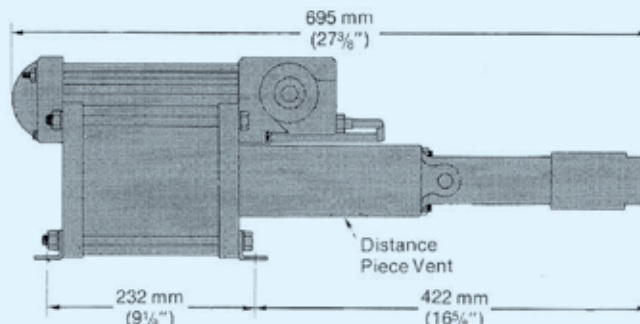

**Models DGF, DGSF, DGSTV nominal ratio 35, 60 100:1**

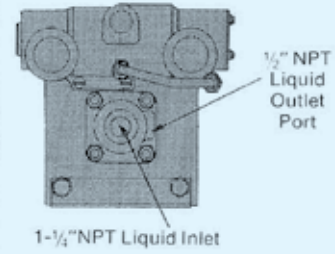

End dimensions as GW/GSF

Net weight 57 lbs (26 kg)  
 Boxed weight 61 (27 kg)  
 Box size 66 x 41 x 49 cm

If interconnecting piping for the two inlets and two outlets is required, specify modification 29077 with your order.

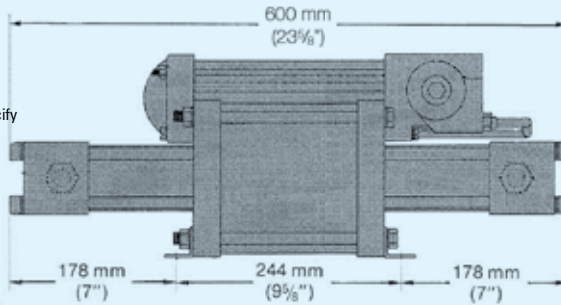
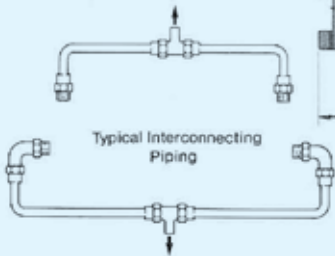

**Models GWD, GSFD nominal ratio 12:1**

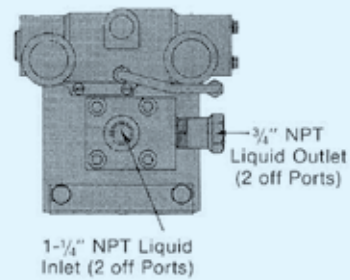

End dimensions as GW/GSF

Net weight 66 lbs (30 kg)  
 Boxed weight 75 lbs (34 kg)  
 Box size 91 x 51 x 39 cm

If interconnecting piping for the two inlets and two outlets is required, specify modification 29078 with your order.

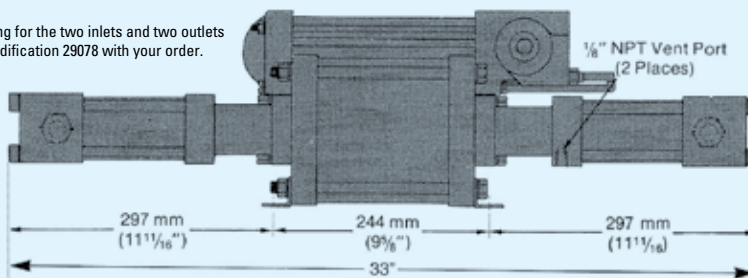

**Models DGFD, DGSFD, DGSTVD nominal ratio 12:1**

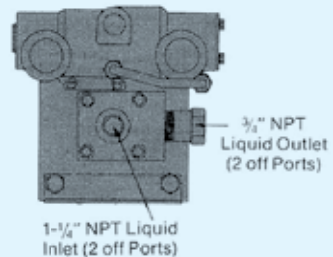

# 8 hp (5.97 kW) Pump Models

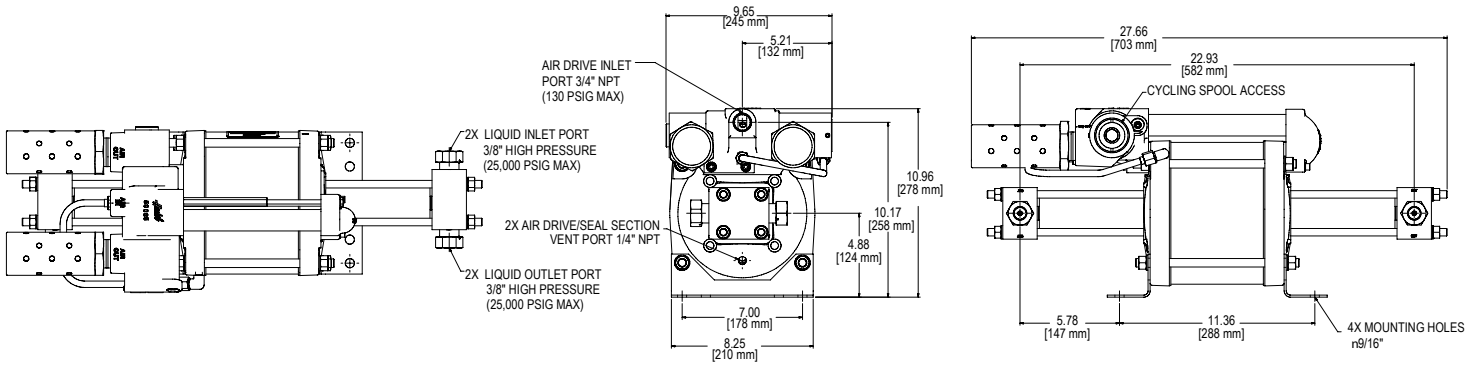

**Models 8HSFD-25, 8FD-25, 8SFD-25**  
**Inlet, Outlet ports 3/8" HP**

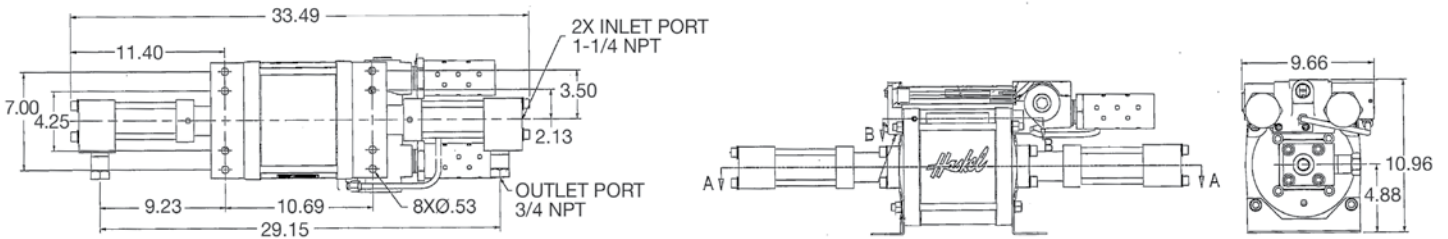

**Models 8DSFD-25 & 8DSTVD-25**

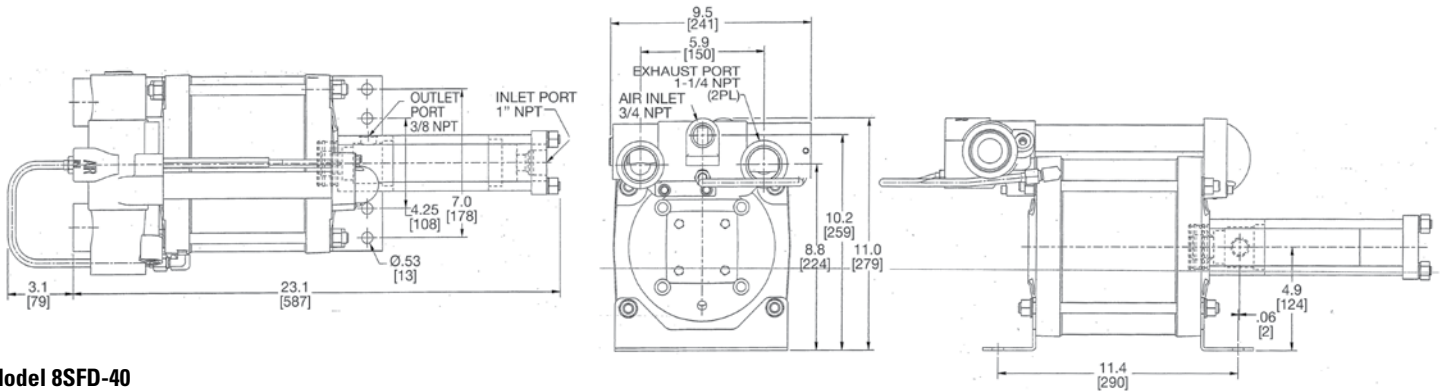

**Model 8SFD-40**

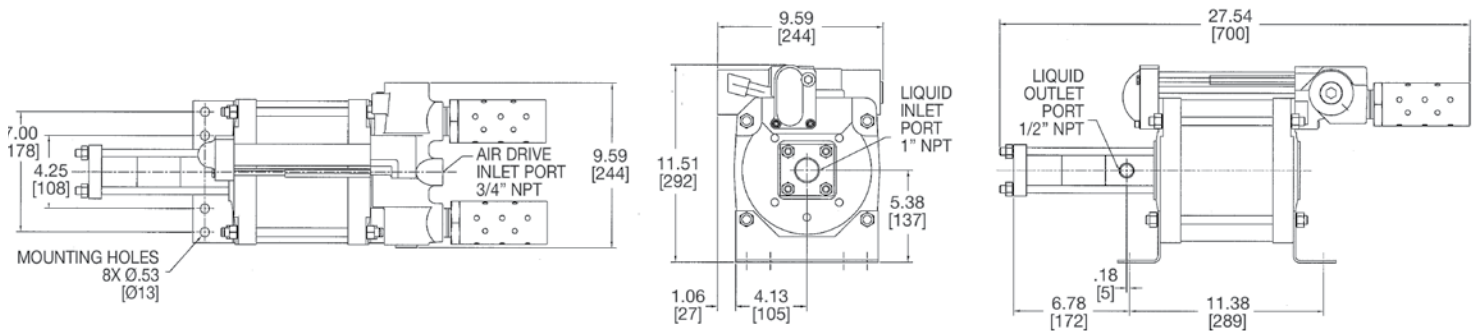

**Model 8SFD-65**

# 8 hp (5.97 kW) Pump Models (cont.)

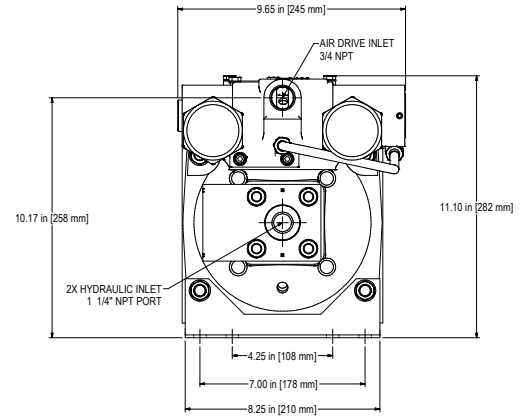
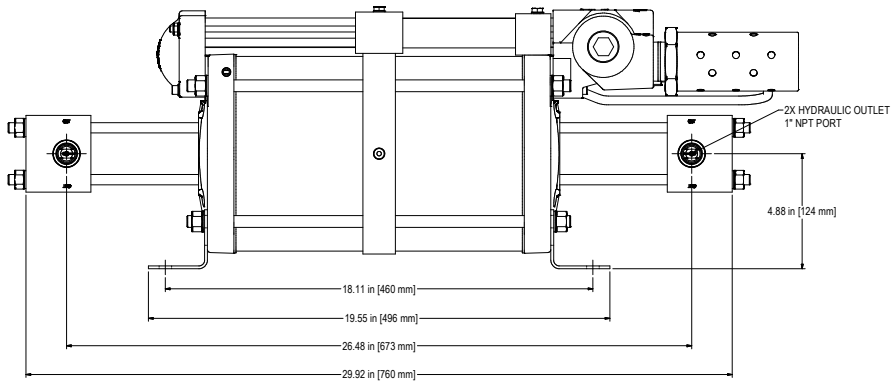
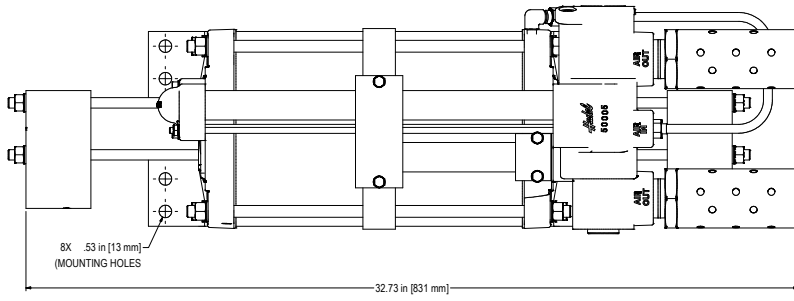

**Model 8SFD2-55**

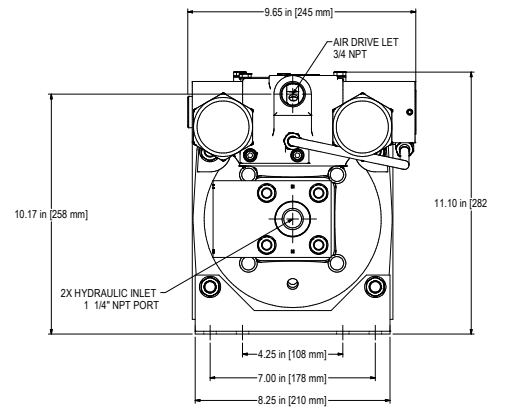
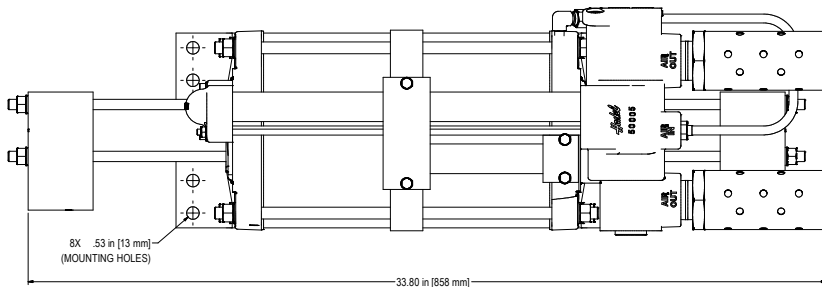

**Model 8SFD2-88**

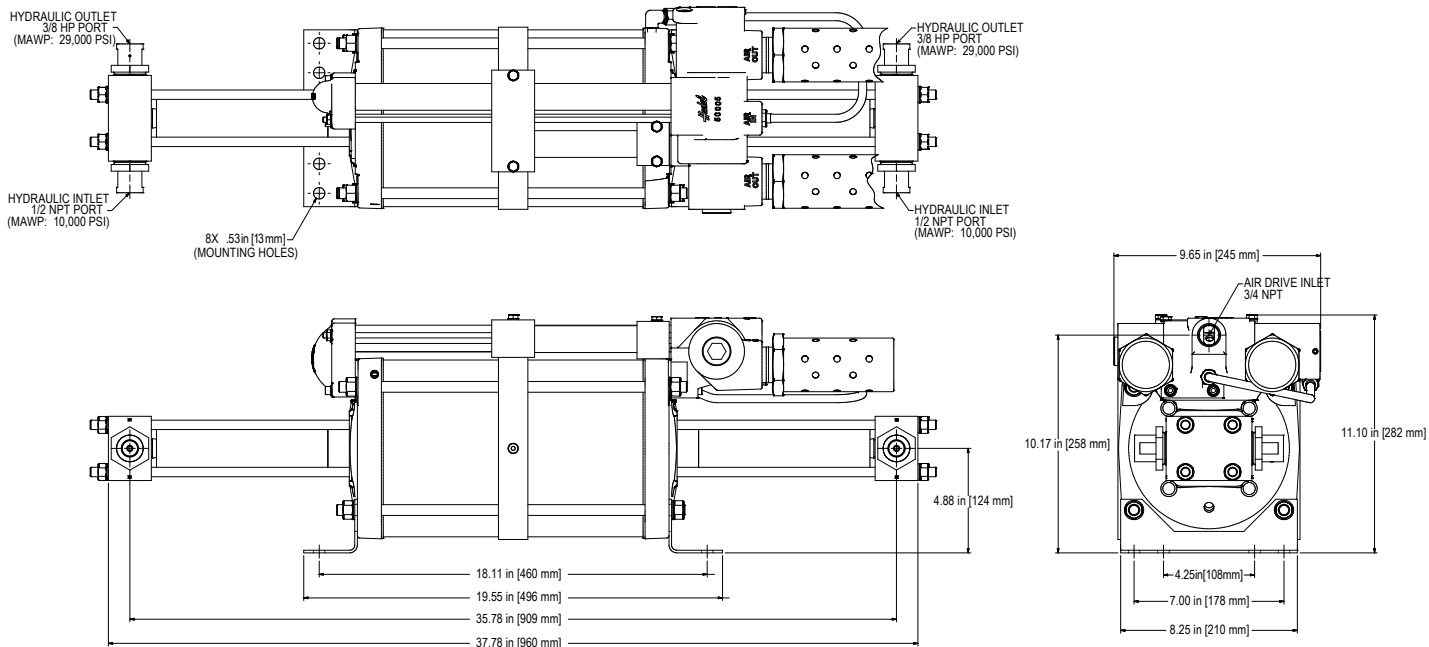

**Model 8SFD2-224**

## 10 hp (7.46 kW) Pump Models

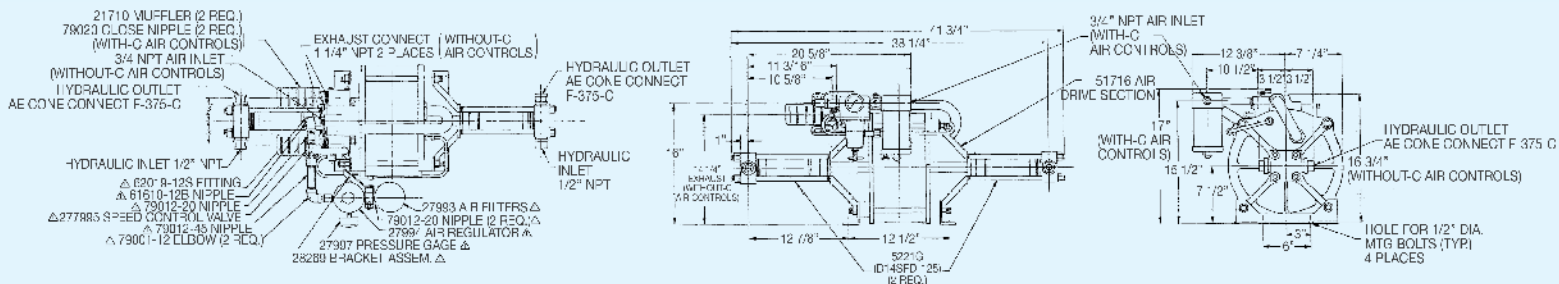

**Model D14STD-125**

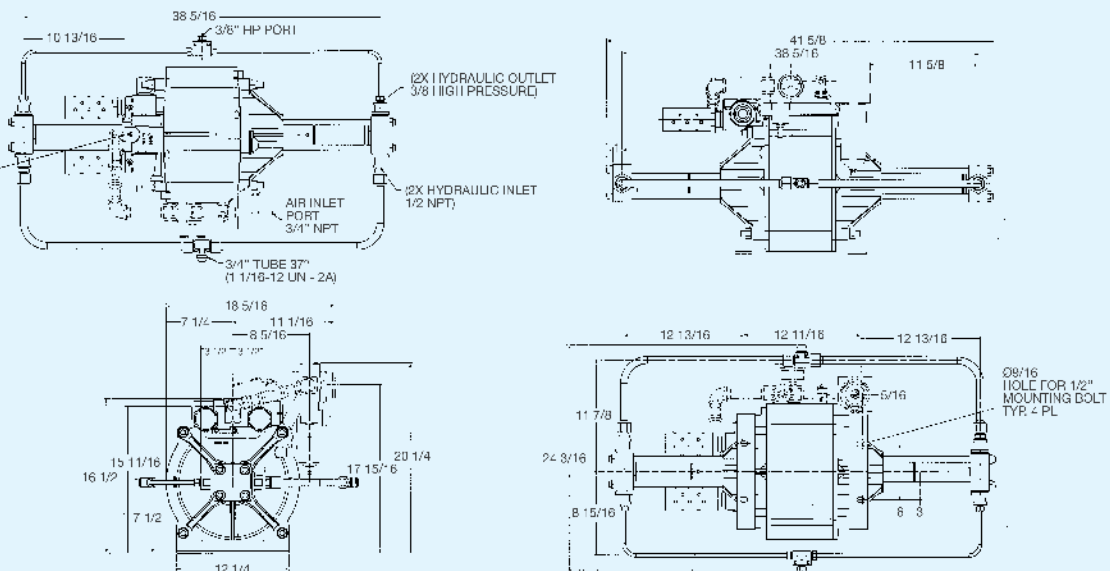

**Model D14STD-315**

CELEBRATING OVER 65  
YEARS OF HYDRAULIC AND  
PNEUMATIC ENGINEERING  
EXPERIENCE IN THE DESIGN  
AND MANUFACTURING  
OF HIGH PRESSURE  
GENERATING EQUIPMENT  
AND CONTROLS



Q05225  
EMS511920

### **Haskel International, LLC.**

100 East Graham Place  
Burbank, CA 91502 USA  
Tel: 818-843-4000 / Fax: 818-556-2549 or 818-841-4291  
Email: [sales@haskel.com](mailto:sales@haskel.com)  
[www.haskel.com](http://www.haskel.com)

### **Haskel Europe Ltd.**

North Hylton Road  
Sunderland SR5 3JD, England UK  
Tel: 44-191-549-1212 / Fax: 44-191-549-0911  
Email: [saleseurope@haskel.com](mailto:saleseurope@haskel.com)  
[www.haskel-europe.com](http://www.haskel-europe.com)

### **Haskel Middle East**

P.O. Box 262384 Jebel Ali, Dubai, United Arab Emirates  
Tel: +971 4 8875656 Fax: +971 4 88 75647  
Email: [sales@haskel.ae](mailto:sales@haskel.ae)

### **Haskel Asia**

23 Tagore Lane #03-06  
Tagore 23 Warehouse Complex, Singapore 787601  
Tel: 65-6455-7559 / Fax: 65-6455-2841  
Email: [sales@haskel.com.sg](mailto:sales@haskel.com.sg)  
[www.haskel.com.sg](http://www.haskel.com.sg)

**For further information on Haskel  
products, please visit us online at  
[www.haskel.com](http://www.haskel.com)**