

Directional Control Valves Section Overview

Enerpac hydraulic valves are available in a wide variety of models and configurations.

Whatever your requirements... directional control, flow control, or pressure control... you can be sure that Enerpac has the correct valve to match your application exactly.

Designed and manufactured for safe operation up to 700 bar, the range of Enerpac valves allows for direct pump mounting, remote mounting, manual or solenoid actuation, and in-line installation, giving you flexible solutions to control your hydraulic system.

Valve Type	Series	Page
Pump Mounted Manual and Solenoid Directional Control Valves	VM VE	114 ▶
Remote Mounted Manual Directional Control Valves	VC	116 ▶
Valve Dimensions	VM VE VC	117 ▶



Pressure and Flow Control Valves
For more hydraulic system control with pressure relief valves, shut-off valves, check valves and sequence valves see our "System Components".

Page: 134



Valving Help
See Basic System Set-Up and Valve Information in our 'Yellow Pages'.

Page: 250



▼ Shown from left to right: VM32, VE33, VM33, VM43L



Reliable Control of Single and Double-Acting Cylinders and Tools

- Advance/Retract and Advance/Hold/Retract operation of single-acting and double-acting cylinders and tools
- Manual or solenoid operation
- Pump mounting will retrofit on most Enerpac pumps
- Available “locking” option on VM Series valves for load-holding applications
- Standard “locking” feature on VE Series 3-position valves
- User adjustable relief valve allows the operator to easily set the working pressure.

▼ ZE-Series electric pump, with VM43 directional valve coupled to a A-65 distribution manifold with V-82 needle valves to operate double-acting jacks in a lifting job.



Valve Operation	Used with Cylinder	Valve Type	
Manual	Single-acting	3-Way, 2-Position	
Manual	Single-acting	3-Way, 3-Position, Tandem Center	
Manual	Double-acting	4-Way, 3-Position, Tandem Center	
Manual	Single-acting	3-Way, 3-Position, Tandem Center, Locking	
Manual	Double-acting	4-Way, 3-Position, Tandem Center, Locking	
Solenoid 24 VDC	Single-acting	3-Way, 2-Position	
Solenoid 24 VDC	Single-acting	3-Way, 2-Position, Dump	
Solenoid 24 VDC	Single-acting	3-Way, 3-Position, Tandem Center	
Solenoid 24 VDC	Double-acting	4-Way, 3-Position, Tandem Center	

For remote valve information, see page 116.

Pump Mounted Directional Control Valves



Adjustable relief valve

All valves feature several gauge ports for “system”, A port and B port pressure monitoring. User adjustable relief valves are included on all models to allow the operator to easily set the optimum working pressure for each application.

VM33 and VE43 valves include “System Check” feature, for more precise pressure holding and improved system control. The VM33 has improved porting which provides faster cylinder retraction while motor is running.

VM VE Series



Max. Flow Capacity:

17 l/min

Maximum Operating Pressure:

700 bar

Model Number	Hydraulic Symbol	Schematic Flowpath			(kg)
		Advance	Hold	Retract	
VM32					2,5
VM33					3,0
VM43					3,1
VM33L					4,8
VM43L					4,9
VE32					3,9
VE32D					3,9
VE33					9,3
VE43					9,3

See page 117 for valve dimensions.



Fittings

For additional fittings see the fitting page of the System Components section in this catalogue.

Page: 125



Locking Valves

For applications that require positive load holding, VM-Series valves (except VM32 valve) are available with a pilot-operated check valve. This option provides hydraulic locking of the load until the valve is shifted into the retract position.



Pendants for VE-Series Solenoid Valves

When ordering Enerpac VE-Series solenoid valves, the pendant must be ordered separately for Z-Class. Pendant connection to be plugged into electric box of pump.

To be used with solenoid valves:	Pendant Model Nr.
VE32D	ZCP-1
VE32, VE33, VE43	ZCP-3

Page: 95

▼ Shown from left to right: VC-20, VC-4L











Remote Control of Single and Double-Acting Cylinders and Tools

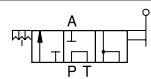
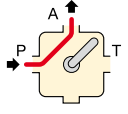
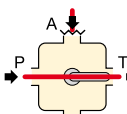
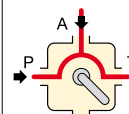
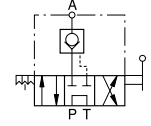

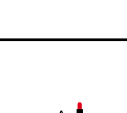
Locking Valves

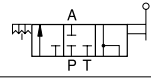
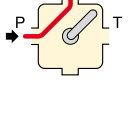
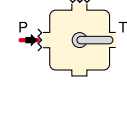
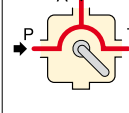
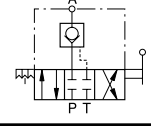
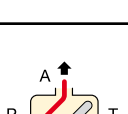
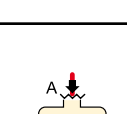
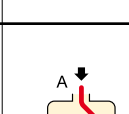
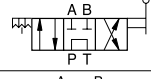
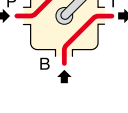
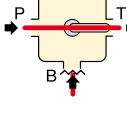
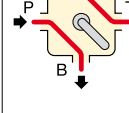
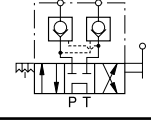
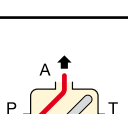
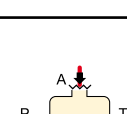
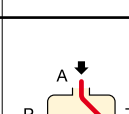
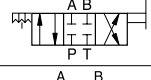
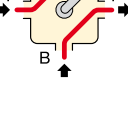
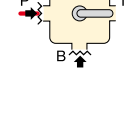
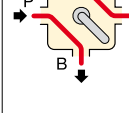
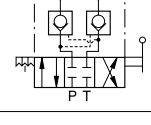
For applications that require positive load holding, VC-Series valves are available with a pilot-operated check valve. This option provides hydraulic locking of the load until the valve is shifted into the retract position.

- Advance/Hold/Retract operation for use with single-acting or double-acting cylinders and tools.

Valve Operation	Used with Cylinder	Valve Type	Model Number	Hydraulic Symbol	Schematic Flowpath			 (kg)
					Advance	Hold	Retract	
Manual	Single-Acting	3-Way, 3-Position, Tandem Center	VC-3					2,9
Manual	Single-Acting	3-Way, 3-Position, Tandem Center, Locking	VC-3L					4,7
Manual	Single-Acting	3-Way, 3-Position, Closed Center	VC-15					2,9
Manual	Single-Acting	3-Way, 3-Position, Closed Center, Locking	VC-15L					4,7
Manual	Double-Acting	4-Way, 3-Position, Tandem Center	VC-4					2,9
Manual	Double-Acting	4-Way, 3-Position, Tandem Center, Locking	VC-4L					4,7
Manual	Double-Acting	4-Way, 3-Position, Closed Center	VC-20					2,9
Manual	Double-Acting	4-Way, 3-Position, Closed Center, Locking	VC-20L					4,7

Return line kit included with remote valves.

Directional Control Valves Dimensions

Pump Mounted Directional Control Valves

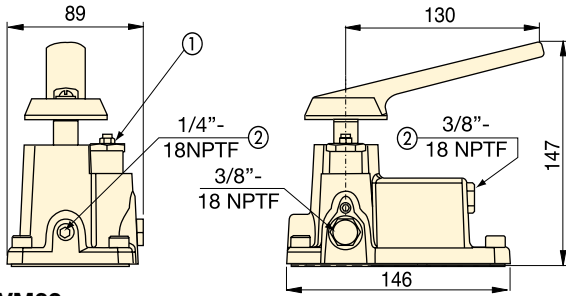

VM32

- ① User Adjustable Relief Valve
- ② Auxiliary Port

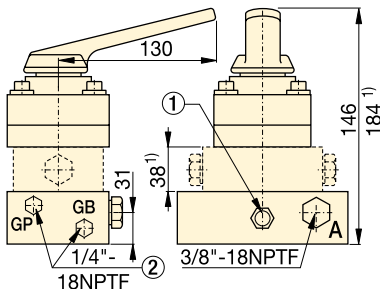

VM33, VM33L, VM43, VM43L

¹⁾ VM33L and VM43L only

VE32D

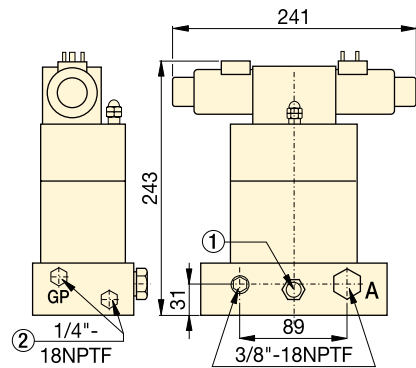
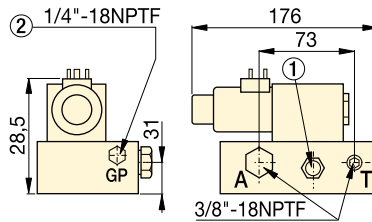

VE33

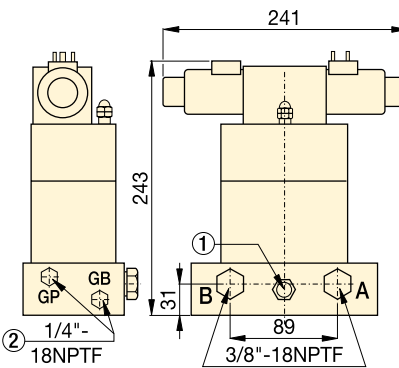

VE43

Remote Manual Directional Control Valves

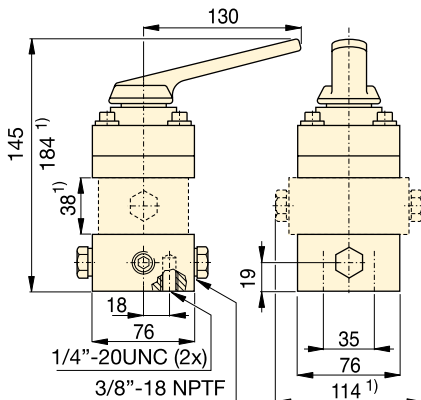

VC-3, VC-3L, VC-15, VC-15L

VC-4, VC-4L, VC-20, VC-20L

¹⁾ VC-3L, VC-15L, VC-4L and VC-20L only

VM VE VC Series



Max. Flow Capacity:

17 l/min

Maximum Operating Pressure:

700 bar



Gauges

Minimize the risk of overloading and ensure long, dependable service from your equipment. Refer to the System Components Section for a full range of gauges.

Page: 128



Fittings

For additional fittings see the fitting page of the System Components section in this catalogue.

Page: 125



Valving Help

See Basic System Set-Up and Valve Information in our 'Yellow Pages'.

Page: 250

System Components & Valves

Enerpac System Components:

All the additional elements you need to complete your high pressure hydraulic system and get started.

Engineered to work with your Enerpac cylinders, pumps and tools, all Enerpac components are designed to the most exacting standards.

With this complete line of hydraulic hoses, couplers, fittings, manifolds, oil and gauges, Enerpac has the accessories to complement your system and ensure the efficient operation, long life and safety of your hydraulic equipment.



Yellow Pages

For sample system set-ups and how to correctly specify your system components, please view the Enerpac “Yellow Pages” section in this catalogue.

Page:  239











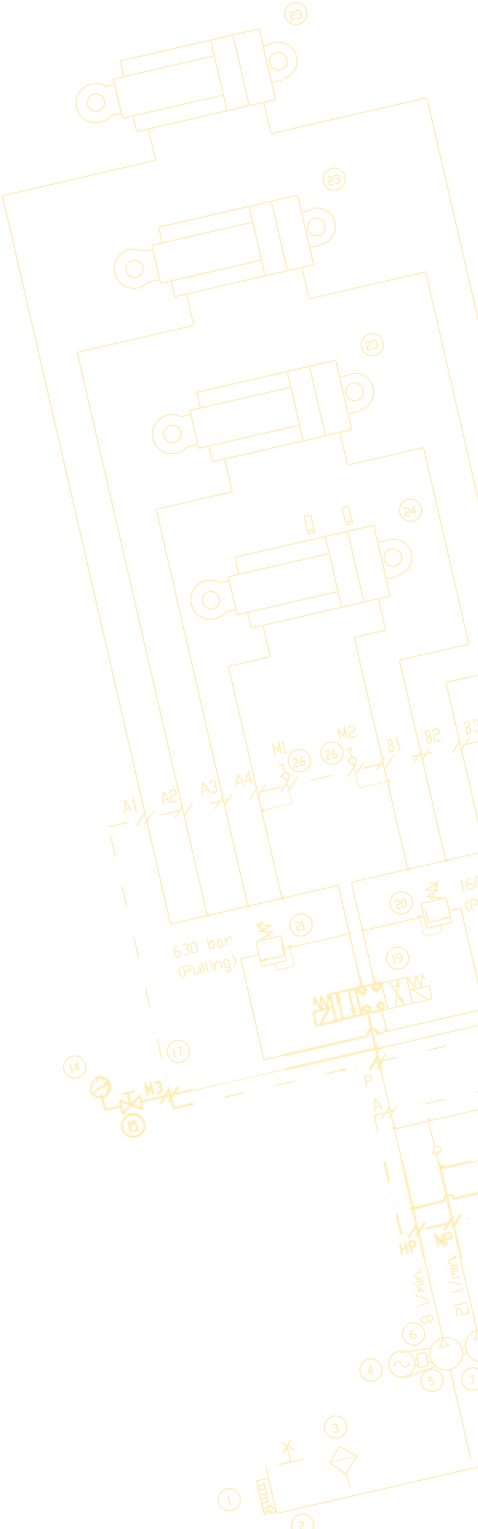



Maintain System Integrity

Use Enerpac System Components, designed to interface with Enerpac cylinders, pumps and tools to ensure your system operates at peak performance.



System Components & Control Valves Overview



Component Type	Series		Page
Hoses	H700		120 ▶
Couplers	A, C, F, T		122 ▶
Hydraulic Oil	HF		124 ▶
Manifolds	A		124 ▶
Control Manifolds	AM		124 ▶
Fittings	BFZ FZ		125 ▶
Force Gauges Pressure Gauges	GF GP		126 ▶
Pressure Gauges, glycerine filled Pressure Gauges, dry	G H		128 ▶
Test System Gauges	T		130 ▶
Digital Pressure Gauges	DGR		131 ▶
Gauge Accessories	GA NV V		132 ▶
Pressure and Flow Control Valves	V		134 ▶

H700-Series, High Pressure Hoses

▼ Shown from top to bottom: HA-7206B, HC-7206, H-7206



Thermo-Plastic Safety Hoses (700-Series)

- For demanding applications, featuring a 4:1 safety factor
- Maximum working pressure of 700 bar
- Outside jacket is polyurethane, to provide maximum abrasion resistance
- Exhibits low volumetric expansion under pressure to enhance overall system efficiency
- Crimped-on rubber strain relief for improved life and durability on all models.

▼ To prevent back pressure and to increase cylinder retraction speed, when using long hoses with single-acting cylinders, the Enerpac HC-7300-Series of hoses with increased internal diameter is the best choice.



Safety and Quality



To ensure the integrity of your system, specify only Enerpac hydraulic hoses.









WARNING !

- Do not exceed 700 bar maximum pressure.
- Do not handle hoses which are under pressure.

More safety instructions in our 'Yellow pages'.

Page: 240

▼ Hose End Couplings

1/4" NPTF	
3/8" NPTF	
A-604	
A-630	
AH-604	
AH-630	
C-604	
CH-604	

High Pressure Hydraulic Hoses

H700 Series



Inside Diameter:

6,4 - 9,7 mm

Length:

0,6 - 15 m

Maximum Operating Pressure:

700 bar

Internal Diameter (mm)	Hose End Assemblies and Couplers *		Hose Length (m)	Model Number	 (kg)	
	End one	End two				
6,4	1/4" NPTF		-	-	-	
			-	-	-	
		A-630	1,8	HB-7206QB	1,1	
			-	-	-	
		CH-604	1,8	HC-7206Q	1,0	
	3/8" NPTF	3/8" NPTF		0,6	H-7202	0,5
				0,9	H-7203	0,7
				1,8	H-7206	0,9
				3,0	H-7210	1,4
				6,1	H-7220	2,8
				9,1	H-7230	4,5
				15	H-7250	7,0
				-	-	-
		A-604	1,8	HA-7206B	1,1	
			-	-	-	
		AH-604		-	-	-
				1,8	HA-7206	1,0
				3,0	HA-7210	1,5
			AH-630	1,8	HB-7206	1,0
			C-604		0,9	HC-7203B
				1,8	HC-7206B	1,3
	3,0	HC-7210B		1,8		
CH-604		0,9	HC-7203	0,8		
		1,8	HC-7206	1,0		
		3,0	HC-7210	1,5		
		6,1	HC-7220	2,9		
CH-604	CH-604		1,8	HC-7206C	1,1	
			15	HC-7250C	7,0	
9,7	3/8" NPTF	3/8" NPTF	1,8	H-7306	1,6	
				-	-	-
				3,0	H-7310	2,4
				6,1	H-7320	4,5
				9,1	H-7330	7,3
			15	H-7350	11,5	
		CH-604		1,8	HC-7306	1,7
				3,0	HC-7310	2,5
				6,1	HC-7320	5,1

* For technical information on couplers see next page.



Torque Wrench Hoses

Use Enerpac twin safety hoses with double-acting wrenches to ensure the integrity of your hydraulic system.

Page: **202**



Fittings

For additional fittings see the fitting page of the System Components section.

Page: **125**

Hose Oil Capacity

When using greater hose lengths, it is sometimes necessary to fill the pump reservoir after filling the hoses. To determine the hose oil capacity, use the following:

For 6,4 mm inside diameter hoses:
Capacity (cm³) = 32,1699 x Length (m)

For 9,7 mm inside diameter hoses:
Capacity (cm³) = 73,8981 x Length (m)

▼ Shown: FH-604, FR-400, AR-630, C-604, AH-604, AR-400



3/8" High Flow Couplers

- Standard equipment on most Enerpac cylinders
- Recommended for use on all Enerpac pumps and cylinders where space and porting permits
- Includes "2-in-1" dust cap for use on male and female couplers

3/8" High Pressure 'Flush-face' Couplers

- Featuring "Push-to-connect" operation, to guarantee good connection every time
- Flush-face, zero-leak operation for minimal spillage
- HTMA* recognized for safety and performance
- Will not interchange with low pressure couplers

3/8" Regular Spee-D-Couplers®

- For medium duty applications with hand pumps
- Includes female aluminium dust cap

1/4" Regular Couplers

- For use with small cylinders and hand pumps
- Includes female aluminium dust cap

1/4" Spin-on Torque Wrench Couplers

- For use with 700 bar S and W-Series torque wrenches, THQ-Series hoses and 700 bar torque wrench pumps

1/4" Lock-ring Torque Wrench Couplers

- For use with 800 bar HXD and SQD-Series torque wrenches, THC-Series hoses and 800 bar torque wrench pumps.

* Hydraulic Tool Manufacturers Association.

Quick Connection of Hydraulic Lines



Thread sealer

To seal NPTF threads use one of the new anaerobic thread sealers or Teflon paste. When using Teflon Tape, apply the tape one thread from the end of a fitting to prevent it from winding up in the hydraulic system.



WARNING!

Couplers should be pressurized only when completely connected and should not be coupled or uncoupled when pressurized.

More safety instructions in our 'Yellow Pages'.

Page: 240



F-Series

Flush-faced couplers provide reduced pressure drop versus other types and are preferred in dirty, grimy construction and mining environments due to easy clean, non-dirt trapping faces.

▼ With the use of Enerpac high flow couplers, hoses are easily installed for multiple hydraulic line connections in this 34 points PLC-controlled lifting system.



Hydraulic Couplers



CT-604 Safety Tool

Use the Enerpac CT-604 to relieve hydraulic back pressure by safely bleeding the hydraulic coupler.

NOTE: For use on C-Series 700 bar High-Flow Couplers only

Minimize injuries from projectile parts and under-skin hydraulic fluid injections by eliminating unsafe coupler bleeding practices. The CT-604 is Enerpac-engineering safe for use at 700 bar.

A, C, F, T Series



Maximum Flow Capacity:
6,1 - 40,0 l/min

Thread:
1/4" - 3/8" NPTF

Maximum Operating Pressure:
700 - 800 bar

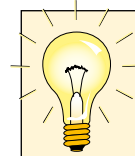
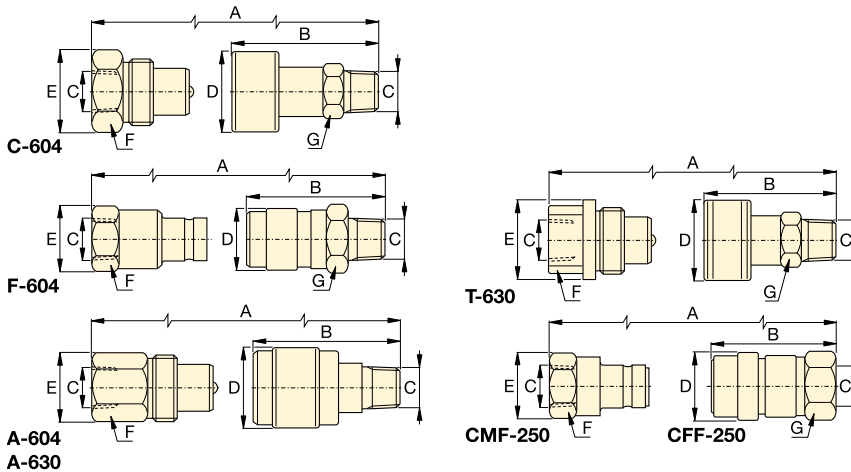

Metal Dust Caps

Steel dust caps are available for the C-604 series couplers.

Order model number:
CD-411M for female half
CD-415M for male half

Maximum Flow Capacity (l/min)	Coupler Type	Model Numbers			Dimensions (mm)							Dust Cap(s) Modelnr.
		Complete Set	Female Half	Male Half	A*	B	C	D	E	F	G	
35	700 bar High-Flow Coupler 	C-604	CR-400	CH-604	83	64	3/8" NPTF	35	36	32	25	(2x) CD-411
40	700 bar Flush-Face coupler 	F-604	FR-400	FH-604	111	72	3/8" NPTF	31	31	27	29	-
7,6	700 bar Regular Spee-D-Coupler® 	A-604	AR-400	AH-604	77	42	3/8" NPTF	28	26	23	19	Z-410 female only
7,6	700 bar Regular Coupler 	A-630	AR-630	AH-630	66	35	1/4" NPTF	22	20	19	15	Z-640 female only
11,4	700 bar Spin-on Coupler 	T-630	TR-630	TH-630	73	60	1/4" NPTF	29	29	19	21	-
6,1	800 bar Lock-ring Coupler 	-	CFF-250	CMF-250	76	58	1/4" NPTF	23	28	24	22	-

* Value A is total length when male and female half are connected.

▼ Shown: A-65, FZ-1625, HF-95Y, FZ-1634, FZ-1607, A-64, AM-21



The Genuine Range

Hydraulic Oil

Contents	Model Number	Use only genuine Enerpac Hydraulic Oil. The use of any other fluid will render your Enerpac warranty null and void.
1 litre	HF-95X	
5 litres	HF-95Y	
20 litres	HF-95T	

▼ OIL SPECIFICATION CHART

Viscosity Index	100 min
Viscosity at 210°F	42/45 S.U.S.
Viscosity at 100°F	150/165 S.U.S.
Viscosity at 0°F	<12,000 S.U.S.
API Gravity	31.0/33.0
Flash, C.O.C. °F	400
Pour Point, °F	-25
Aniline Point, °F	210/220
Paraffinic Base Colour	Blue

- Maximum pump volumetric efficiency
- Maximum internal heat transfer
- Prevents pump cavitation
- Additives prevent rust, oxidation and sludge
- High viscosity index
- Maximum film protective lubricity.

Manifolds

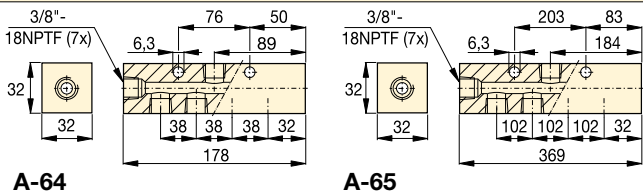
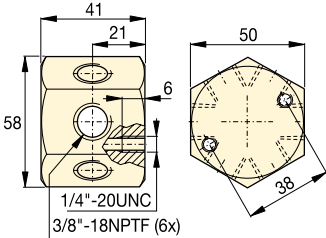
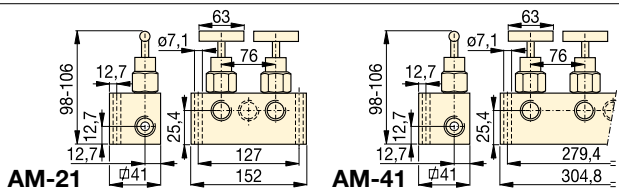
Description	Model Number	Dimensions (mm)
7-port Manifold, short 7-port Manifold, short allows direct mounting of control valves to the manifold.	A-64 A-65	
6-port Manifold, hexagon Plugs furnished for all ports 3/8"-18 NPTF.	A-66	
Control Manifolds For control of two or four single-acting cylinders simultaneously. AM-21 with 5 ports 3/8"NPTF. AM-41 with 7 ports 3/8"NPTF.	AM-21 AM-41	

Hydraulic Oil, Manifolds and Fittings











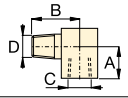

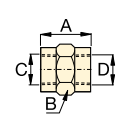

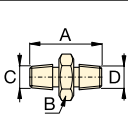

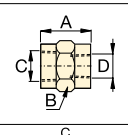

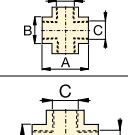

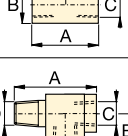

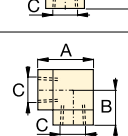

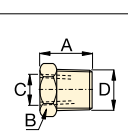

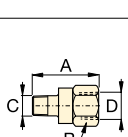
3/8" Swivel Connector

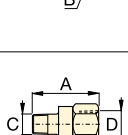
360 degree swivel coupler for optimal orientation of the hydraulic connection on cylinders, pumps and hoses. Order Model Nr. XSC-1.

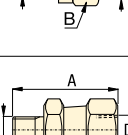
**A, AM
BFZ
FZ
HF
Series**

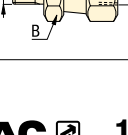

700 bar Fittings		Model Number	Dimensions (mm)				Diagram	
			A	B	C	D		
Street Elbow			FZ-1616	23	33	3/8"-18 NPTF	3/8"-18 NPTF	
From: 3/8"-NPTF Male	To: 3/8"-NPTF Female							
Reducing Connector			FZ-1615	28	25	3/8"-18 NPTF	1/4"-18 NPTF	
From: 3/8"-NPTF Female	To: 1/4"-NPTF Female							
			FZ-1625	47	29	1/2"-14 NPTF	3/8"-18 NPTF	
From: 1/2"-NPTF Female	To: 3/8"-NPTF Female							
Hexagon Nipple			FZ-1608	38	16	1/4"-18 NPTF	1/4"-18 NPTF	
From: 1/4"-NPTF	To: 1/4"-NPTF							
From: 3/8"-NPTF	To: 3/8"-NPTF							
From: 3/8"-NPTF	To: 3/8"-NPTF							
Coupling			FZ-1614	29	23	3/8"-18 NPTF	3/8"-18 NPTF	
From: 3/8"-NPTF	To: 3/8"-NPTF							
			FZ-1605	29	19	1/4"-18 NPTF	1/4"-18 NPTF	
From: 1/4"-NPTF	To: 1/4"-NPTF							
Cross			FZ-1613	45	25	3/8"-18 NPTF	-	
From: 3/8"-NPTF Female	To: 3/8"-NPTF Female							
Tee			FZ-1612	45	25	3/8"-18 NPTF	-	
From: 3/8"-NPTF	To: 3/8"-NPTF							
			FZ-1637	45	24	1/4"-18 NPTF	-	
From: 1/4"-NPTF	To: 1/4"-NPTF							
Street Tee			BFZ-16312	56	26	3/8"-18 NPTF	3/8"-18 NPTF	
From: 3/8"-NPTF Female	To: 3/8"-NPTF Male							
Elbow			FZ-1610	33	20	3/8"-18 NPTF	-	
From: 3/8"-NPTF	To: 3/8"-NPTF							
			FZ-1638	36	24	1/4"-18 NPTF	-	
From: 1/4"-NPTF	To: 1/4"-NPTF							
Reducer			FZ-1630	19	19	1/4"-18 NPTF	3/8"-18 NPTF	
From: 3/8"-NPTF	To: 1/4"-NPTF							
From: 1/4"-NPTF	To: 1/2"-NPTF							
			BFZ-1630	28	22	1/4"-18 NPTF	1/2"-14 NPTF	
From: 1/4"-NPTF	To: 1/2"-NPTF							
From: 3/8"-NPTF	To: G1/4"							
Adaptor			BFZ-16411	35	19	1/4"-18 NPTF	G1/4"	
From: G1/4"	To: 1/4"-NPTF							
From: G1/4"	To: 1/8"-NPTF							
From: G3/8"	To: 1/4"-NPTF							
			BFZ-16421	31	19	1/8"-27 NPTF	G1/4"	
From: G3/8"	To: 1/4"-NPTF							
From: G3/8"	To: 1/4"-NPTF							
From: G3/8"	To: 3/8"-NPTF							
Adaptor			FZ-1055	44	23	1/4"-18 NPTF	3/8"-18 NPTF	
From: 1/4"-NPTF	To: 3/8"-NPTF							
From: 1/4"-NPTF	To: 1/8"-NPTF							
			FZ-1642	30	19	1/8"-27 NPTF	1/4"-18 NPTF	
From: 1/4"-NPTF	To: 1/8"-NPTF							
			FZ-1634	42	28	3/8"-18 NPTF	1/2"-18 NPTF	
From: 1/2"-NPTF	To: 3/8"-NPTF							
Swivel Fitting			FZ-1660	40	22	3/8"-18 NPTF	3/8"-18 NPTF	
From: 3/8"-NPTF Male	To: 3/8"-NPTF Female							

Hydraulic Force & Pressure Gauges

▼ Shown from left to right: GF-230B, GF-835B, GP-10S



- **GF-series gauges:** calibrated with dual scale reading for pressure and force in bar and kN
- **GF-series gauges:** all pressure sensing parts are sealed and damped by glycerine for long life
- **GP-series gauges:** calibrated with dual scale reading for pressure in bar and psi
- **Excellent readability:** gauge face dimensions 100 mm
- **Fast, easy installation**
- **Stainless steel gauge cases for corrosion resistance.**

▼ A GP-10S gauge is used on this press to check the hydraulic pressure required to bend flat steel bar.



Visual Reference for System Pressure and Force



Auto-Damper Valve V-10

For automatic control of gauge fluctuations, the V-10 Auto-Damper Valve controls the movement of the gauge needle by restricting oil flow in and out of the gauge. No adjustments needed.



Page: 134



Snubber Valve V-91

Infinitely adjustable for metering oil out of a gauge. The V-91 Snubber Valve is also suitable as a shut-off valve to protect the gauge during high cycle applications.

Page: 134

	Used With
	All Cylinders
	All Cylinders
	All 5 ton Cylinders
	All 10 ton Cylinders
	All 25 ton RC-Cylinders
	All 50 ton RC, RR-Cylinders
	13 ton RCH-Series
	RCS-201, 302
	RCS-502, 1002
	RCH-202, 302, 603
	All 25, 30, 50 ton cylinders
	All 75, 100 ton cylinders
	All 150, 200 ton cylinders
	10 ton VLP Presses
	25 ton XLP Presses
	50 ton XLP, BPR Presses
100 ton VLP, BPR Presses	
200 ton VLP, BPR Presses	

Hydraulic Force & Pressure Gauges



Maximum Indicator Pointer

Indicator retains peak readings of pressure or force generated by the system.

Can easily be installed on GP and H-Series gauges.
Order model nr: **BSA-881**.



Pressure Gauges

To measure the input pressure into cylinders or high pressure systems. Also for all testing applications.

Force Gauges

To measure external load supported by a cylinder or jack in kN. For pressing parts together under pre-determined loads, weighing, testing, etc.

GP-Series are dry gauges.

GF-Series are glycerine filled gauges.

GF GP Series



Pressure Range:

0 - 1000 bar

Force Range:

0 - 2000 kN

Gauge Face Diameter:

100 mm

Accuracy, % of full scale:

± 1%

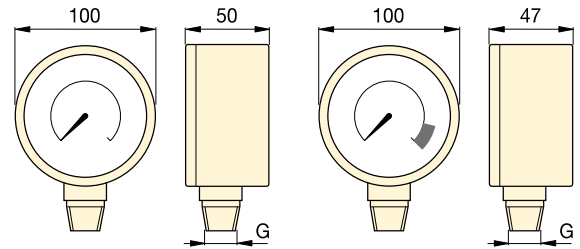

GP-serie

GF-serie

Gauge Type and Calibration				Units per Division	Model Number *	Thread G	Gauge Adaptor			
bar		psi					Required			
bar		psi		bar		kN		GA-1	GA-2	GA-3
0-700		0-10.000		-		-		●	●	
0-1000		0-15.000		-		-		●	●	
-		-		0-700		0-45		●	●	
-		-		0-700		0-100		●	●	
-		-		0-700		0-232		●	●	
-		-		0-700		0-500		●	●	
-		-		0-700		0-124		●	●	
-		-		0-700		0-175/275		●	●	
-		-		0-700		0-450/900		●	●	
-		-		0-700		0-210/320/570				●
-		-		0-700		0-232/300/500				●
-		-		0-700		0-720/930				●
-		-		0-700		0-1400/2000				●
-		-		0-700		0-100		●	●	
-		-		0-700		0-232		●	●	
-		-		0-700		0-500		●	●	
-		-		0-700		0-720/930				●
-		-		0-700		0-1400/2000				●

* GF-Series Force gauges with imperial scale reading (psi, lbs) are available by changing the suffix 'B' into 'P'.

▼ Shown from left to right: H4049L, G-2534R, G-4089L, G-2535L, G-4040L



Visual Reference of System Pressure

Glycerine Filled (G-Series)

- Dual scale reading calibrated in bar and psi
- All pressure sensing parts sealed and dampened by glycerine for long life
- Includes safety blow-out disk and pressure equalizing membrane
- Gauge snubbers or needle valves recommended for high cycle applications.

High Cycle Dry Gauges (H-Series)

- Dual scale reading calibrated in bar and psi
- Ideal for use in many applications, specifically for high cycle and harsh environments
- Gauge snubbers or needle valves recommended to shut off gauge when not in use.

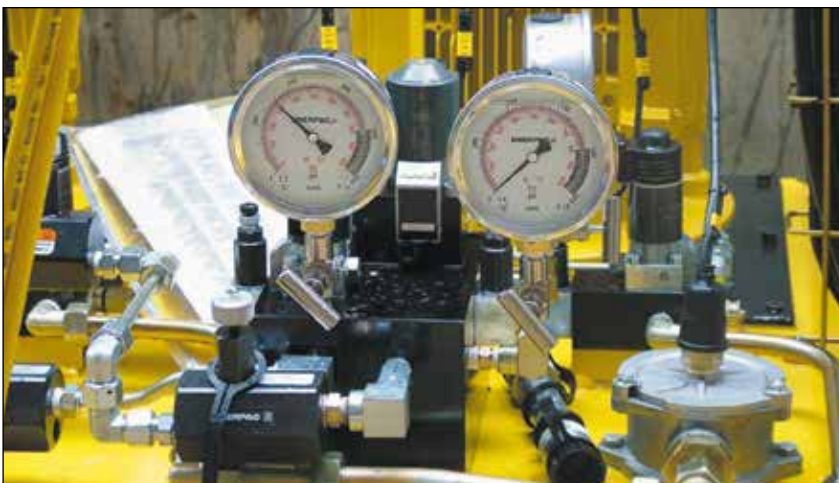

Gauge adaptor

For easy gauge installation into almost any system, Enerpac offers a complete line of gauge adaptors.

Page: 132



Snubber Valve V-91

Infinitely adjustable for metering oil out of a gauge. The V-91 Snubber Valve is also suitable as a shut-off

valve to protect the gauge during high cycle applications.

Page: 134

◀ When lifting or pressing, always use a gauge. A gauge is your 'window' to the system. It lets you see what's going on.

Hydraulic Pressure Gauges

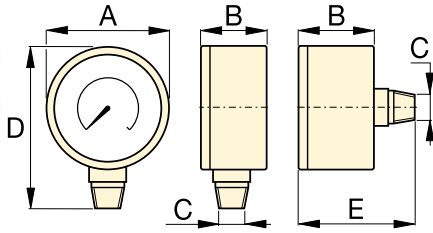

Size (mm)	Connection	Dimensions (mm)				
		A	B	C	D	E
63	Lower Mount	63	37	¼" NPTF	84	-
63	Center Rear	63	37	¼" NPTF	-	63
100	Lower Mount	100	29	¼" NPTF	121	-
100	Lower Mount	100	49	½" NPTF	136	-

Note: dimensions for reference only.

G H Series



Pressure Range:

0 - 1000 bar

Face Diameter:

63 - 100 mm

Accuracy, % of full scale:

± 1,0 - 1,5%



Maximum Indicator Pointer

Indicator retains peak readings of pressure or force generated by the system.

Can easily be installed on GP and H-Series gauges.

Order model nr: **BSA-881**.

▼ SELECTION CHART

Gauge Series	Pressure Range		Model Number				Major Graduation		Minor Graduation		Major Graduation		Minor Graduation	
			ø 63 ¼" NPTF Lower Mount	ø 63 ¼" NPTF Center Rear	ø 100 ¼" NPTF Lower Mount	ø 100 ½" NPTF Lower Mount	bar		psi		bar		psi	
	(bar)	(psi)	Accuracy: ± 1,5 %		Accuracy: ± 1,0 %		ø 63	ø 100	ø 63	ø 100	ø 63	ø 100	ø 63	ø 100
G-Series	0-7	0-100	G2509L	-	-	-	1	-	0,01	-	10	-	2	-
	0-11	0-160	G2510L	-	-	-	1	-	0,02	-	10	-	2	-
	0-14	0-200	G2511L	-	-	-	1	-	0,02	-	50	-	5	-
	0-20	0-300	G2512L	-	-	-	5	-	0,50	-	50	-	5	-
	0-40	0-600	G2513L	-	-	-	10	-	1	-	100	-	10	-
	0-70	0-1.000	G2514L	G2531R	-	-	10	-	1	-	100	-	20	-
	0-140	0-2.000	G2515L	-	-	-	10	-	5	-	500	-	50	-
	0-200	0-3.000	G2516L	-	-	-	50	-	5	-	500	-	50	-
	0-400	0-6.000	G2517L	G2534R	-	-	100	-	10	-	1000	-	100	-
	0-700	0-10.000	G2535L	G2537R	G4088L	G4039L	100	100	10	10	2000	1000	200	100
0-1000	0-15.000	G2536L	G2538R	G4089L	G4040L	100	100	20	20	3000	3000	200	200	
H-Series	0-700	0-10.000	-	-	H4049L	H4071L	-	100	-	10	-	1000	-	100

Test System Gauges

▼ Gauge shown: T-6003L



- Dual scale reading calibrated in bar and psi
- All gauges have spring-loaded backs with rubber blow-out plugs to protect case assembly in case of over-pressurization
- Integral maximum indicator pointer standard included
- 2800 and 3500 bar models include flange mounting
- 1/2" NPTF versions are made of high strength alloy steel
- 0.25" cone models are made of 316 stainless steel, with 403 stainless steel on 2800 and 3500 bar models.

▼ An Enerpac P-2282 hand pump equipped with a T-6011L test system gauge is used for proof pressure testing of hydraulic valves.



T Series

Pressure Range:
0 - 3500 bar

Face Diameter:
162 - 192 mm

Accuracy, % of full scale:
± 0,5 - 1,5%



Cone Mount Gauge Adaptor

Contains fittings to connect 1/4" cone fitting gauge to 3/8" cone system. Kit includes 43-301 tee and 43-704 gauge adaptor. Order model number: **83-011**.

Page: **75**



Cone Mount Gauge Connector

For connecting gauges with 0.25" cone fitting directly to model number **11-100** or **11-400** pump (page 74). May be used with other 0.25" cone systems. Order model number: **43-704**

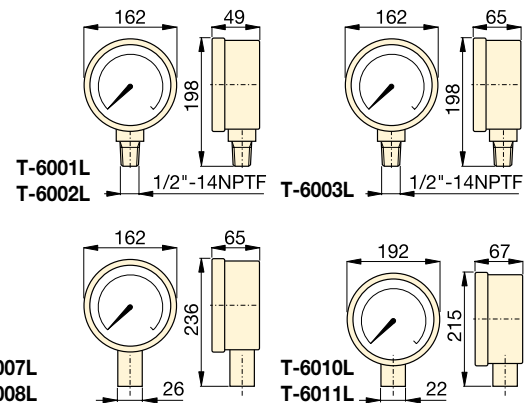

Pressure Range (bar)	Pressure Range (psi)	Model Number		Number Intervals (bar)	Graduation Intervals (bar)	Number Intervals (psi)	Graduation Intervals (psi)
		Alloy Steel 1/2" NPTF	Stainless Steel 0,25 cone				
0-70 ¹⁾	0-1000	T-6001L	-	10	1	100	10
0-350 ¹⁾	0-5000	T-6002L	-	50	5	500	50
0-700 ¹⁾	0-10.000	T-6003L	T-6007L	100	10	1.000	100
0-1400 ¹⁾	0-20.000	-	T-6008L	200	20	1.000	100
0-2800 ²⁾	0-40.000	-	T-6010L	500	20	5.000	200
0-3500 ²⁾	0-50.000	-	T-6011L	500	50	5.000	200

¹⁾ Accuracy ± 0,5%

²⁾ Accuracy ± 1,5%

Digital Hydraulic Pressure Gauge

▼ Gauge shown: **DGR-2**



- Rated for system pressure up to 1380 bar
- Displays high pressure in bar, psi, MPa and kg/cm²
- Zero reset - ensures that gauge reads actual pressure
- IP65 protection
- 3 Volt battery included (type CR2430).

DGR Series

Pressure Range:
0 - 1380 bar

Voltage:
3 Volt (battery)

Accuracy, % of full scale:
± 0,25%



Gauge adaptor

For easy gauge installation into almost any system, Enerpac offers a complete line of gauge adaptors.

Page: 132

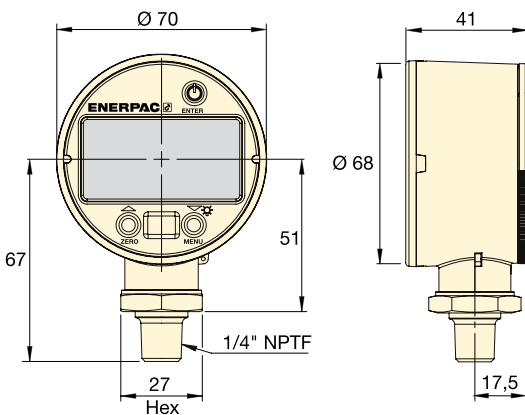

High Pressure Rating (bar)		High Pressure Rating (MPa)		Model Number	High Pressure Rating (psi)		High Pressure Rating (kg/cm ²)	
Range	Interval	Range	Interval		Range	Interval	Range	Interval
0-1380	0,07	0-140	0,01	DGR-2	0-20.000	1	0-1400	0,07

Weight: 0,23 kg.

▼ Greater accuracy and easier to read: enhance your ability to monitor and control hydraulic system pressure up to 1380 bar.



Gauge Accessories

▼ Shown from left to right: GA-3, V-91, GA-1, GA-2, GA-4, NV-251, GA-918



GA, NV, V Series

Operating Pressure:
700 bar

▼ A gauge is easily installed into your hydraulic system using a gauge adaptor.



Gauge Adaptors (GA-Series)

- For easy mounting of a pressure gauge onto your system
- Male end screws into pump or cylinder port, female end accepts hose or coupler, 3rd port is for gauge connection
- GA-918 provides for swivel connection.

Model Number	Gauge Port (NPTF)	Male End (NPTF)	Female End (NPTF)	Dimensions (mm)					
				A	B	C	D	E	F
GA-1	1/2"	3/8"	3/8"	71	31	1/2" NPTF	3/8" NPTF	3/8" NPTF	32
GA-2	1/2"	3/8"		155	35	1/2" NPTF	3/8" NPTF	3/8" NPTF	32
GA-3	1/4"	3/8"		133	48	1/4" NPTF	3/8" NPTF	3/8" NPTF	32
GA-4	1/2"	1/4"		111	35	1/2" NPTF	1/4" NPTF	3/8" NPTF	32

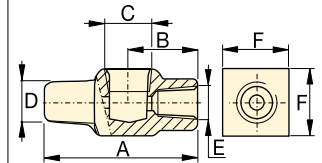

GA-1

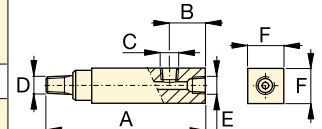

GA-2, GA-3, GA-4



Swivel Adaptor (GA-918)

- Simplifies gauge installation and reading.

Model Number	Dimensions (mm)							
	A	B	C	D	E	S	S1	
GA-918	117	43	1/2" NPTF	28,5	1/2" NPTF	29	38	

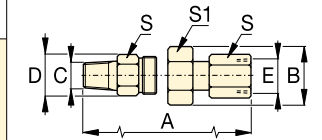

Needle Valves (V- and NV-Series)

- Both NV-251 and V-91 provide positive shut-off
- 303 stainless steel stem, 16 threads/in (NV-251).

Model Number	Orifice (mm)	Thread Size	Dimensions (mm)						
			A	B	C	D	E	F	H
NV-251	4,3	1/4" NPTF	57	29	1/4" NPTF	57	46	19	19
V-91	4,8	1/2" NPTF	89	32	1/2" NPTF	64	32	37	37

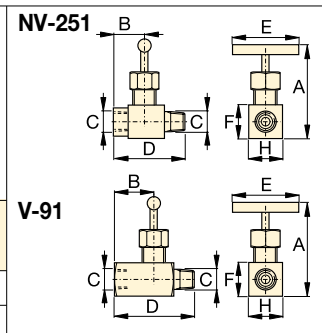

Enerpac Application Ideas

By using only Enerpac branded oil and couplers, you are protecting the integrity of your system with components that are designed to work with your Enerpac rams, cylinders, pumps and tools. Protect your investment and personnel, demand only Enerpac accessories.



▲ H700-Series Hydraulic Hoses

Enerpac H700-Series hydraulic hoses are designed to provide the best performance of your Enerpac products. Available in thermoplastic construction, a number of lengths and internal diameters, and with a number of end-configurations, there will be an Enerpac hose to perfectly match your exact application.

C-Series Couplers ▲

Enerpac C-Series couplers provide easy hose and tool connectivity while providing correct performance and pressure ratings to operate most Enerpac products.

G-Series Gauges ►

Enerpac gauges and gauge adaptors make monitoring your systems performance easy while minimizing the risk of overloading and ensuring long, dependable service. Gauges are available to read pressure or force in kN or ton for many Enerpac cylinders.



▼ From left to right: V-152, V-66, V-82, V-161, V-42, V-17



Your Hydraulic Control Solution



Valve Applications

To see these valves used in typical hydraulic circuits, please see our 'Yellow Pages'.

Page: **244**

▼ The V-152 pressure relief valve limits the pressure or force developed in the hydraulic system.

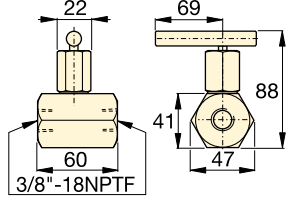
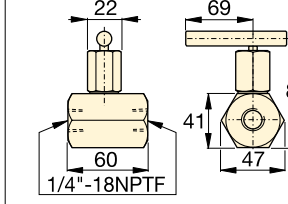
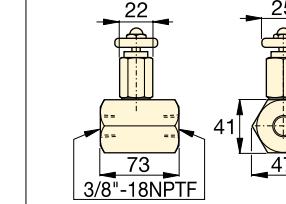
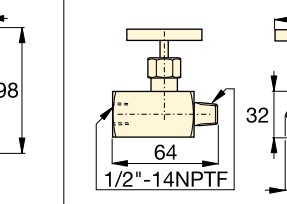
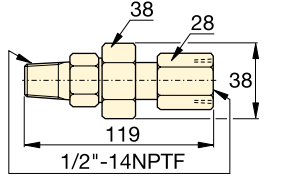
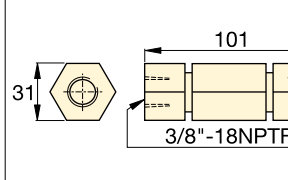
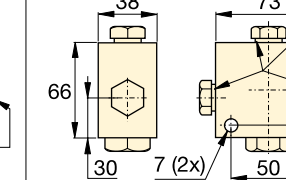
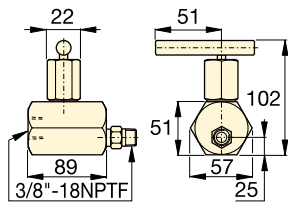
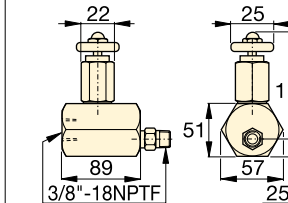
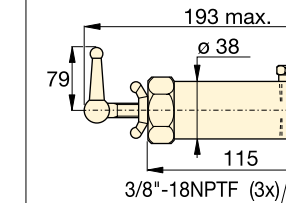
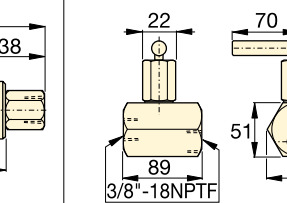

- All valves are rated for 700 bar operating pressure
- All valves feature NPTF porting to insure against leakage at rated pressure
- All valves are painted, coated, or plated for corrosion resistance
- Viton® seals (in V-66NV and V-152NV) for high temperature applications, nickel-plated for maximum corrosion resistance.

 <p>V-82</p>	 <p>V-182</p>	 <p>V-8F</p>	 <p>V-91</p>
 <p>V-10</p>	 <p>V-17</p>	 <p>V-42</p>	
 <p>V-66, V-66NV</p>	 <p>V-66F</p>	 <p>V-152, V-152NV</p>	 <p>V-161</p>

Valve dimensions in mm

Pressure and Flow Control Valves



Control Manifolds

For two or four port manifolds with integral flow control valves, see the manifold page of the System Components section.

Page: 124



Fittings















For additional fittings see the fitting page of the System Components section in this catalogue.

Page: 125

V Series

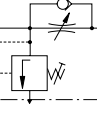

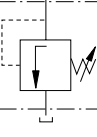
Maximum Operating Pressure:
700 bar

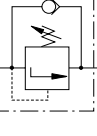
Valve Type and Model Number	Description	Hydraulic Symbol
Needle Valve V-82 V-182 V-8F	 <p>V-82: To control cylinder speed. Can also be used as shut-off valve for temporary load holding. ¼" NPTF female ports. V-182: Same as V-82, but with ⅜" NPTF female ports.</p>	
Snubber Valve V-91	 <p>V-91: Infinitely adjustable for metering oil out of a gauge to prevent snapping of gauge pointer when load or pressure is suddenly released. Also suitable as shut-off valve to</p>	
Auto Damper® Valve V-10	 <p>V-10: To be used when gauge pressure must be monitored during high cycle applications. Creates a flow resistance when load is released suddenly.</p>	
Check Valve V-17	 <p>V-17: Ruggedly built to resist shock and operate with low pressure drop. Closes smoothly without pounding. ⅜" NPTF female port.</p>	
Pilot Operated Check Valve V-42	 <p>V-42: Can be mounted at the cylinder to hold the load in case of system pressure loss. Normally used with double-acting cylinders where pilot port receives pressure from a Tee-</p>	
Manually Operated Check Valve V-66, V-66NV * V-66F	 <p>V-66, V-66NV: For load holding applications with single and double acting cylinders. Valves allow oil to flow back to tank when cylinder retracts. V-66NV with Viton seals,</p>	
Pressure Relief Valve V-152 V-152NV *	 <p>V-152: Limits pressure developed by the pump in hydraulic circuit, thus limiting the force imposed on other components. Valve opens whenever preset pressure is reached.</p>	
Sequence Valve V-161	 <p>V-161: To control oil flow to a secondary circuit. Flow is blocked until system pressure rises to the V-161 setting. When this pressure level is reached, the V-161 opens</p>	

* See page 60 for more information about products for use in high temperature and extreme environment applications.