

# Hydraulic and Mechanical Pullers

Enerpac offers a complete line of pullers with the widest range of sizes, capacities and styles. Whether your application requires mechanical, hydraulic or the patented Posi Lock® system, Enerpac can satisfy your requirements.

Made of high strength steel alloys, you can depend on Enerpac pullers to provide years of trouble-free operation, even in the harshest environments.



## Hydraulic Pullers

These hydraulic pullers eliminate time-consuming and unsafe hammering, heating or prying. Damage to parts is minimized through the use of controlled hydraulic power.



## Posi Lock® Pullers

The puller that meets the safety challenge. A control cage holds the pulling jaws securely in working position. This patented feature reduces the possibility of the puller jaws slipping off the work surface, thereby increasing productivity and tool life and reducing dangerous situations for the user. The Posi Lock® feature is available in a mechanical or hydraulic version.



### WARNING

Do not exceed 50% of the rated puller capacity when using a double crosshead (2 grip arms) or when using puller legs in combination with bearing puller attachment.



### CAUTION!

Not all puller components and configurations are rated at the set capacity. Please contact Enerpac for details.



### IMPORTANT!

Always wear Safety Goggles while using pullers.

# Puller Section Overview

When selecting a puller it is important to consider 3 basic specifications:

### 1. The Capacity:

is the amount of force the puller is capable of producing.

Typically, the capacity required for a job can be determined by using the shaft diameter of the part being pulled.

For manual pullers, the center bolt diameter of the puller should be at least half the diameter of the shaft being pulled from.

For hydraulic pullers, the capacity in tons should be 0,28 to 0,4 times the shaft diameter in mm. Use the following chart:

Shaft Diameter	Puller Capacity
0 - 25 mm	10 ton
25 - 50 mm	20 ton
50 - 89 mm	30 ton
89 - 140 mm	50 ton

### 2. The Reach:

is the distance between the bottom of the base and the jaw flats. The puller's reach must equal or exceed the same distance of the part being pulled.

### 3. The Spread:

is the distance between the jaws. The puller's spread needs to be greater than the width of the part being pulled.

Puller Function	Capacity ton	Puller Type	Series	Page
	8-50	<b>Master Puller Sets</b> Max. Reach: 252 - 700 mm Max. Spread: 250 - 1100 mm	<b>BHP</b>	 150 ▶
	8-50	<b>Grip Puller Sets</b> Max. Reach: 249 - 700 mm Max. Spread: 50 - 580 mm	<b>BHP</b>	 151 ▶
	8-50	<b>Cross Bearing Puller Sets</b> Max. Reach: 354 - 863 mm Max. Spread: 266 - 570 mm	<b>BHP</b>	 152 ▶
	8-50	<b>Bearing Cup Pullers</b> Max. Reach: 110 - 145 mm Max. Spread: 26 - 359 mm	<b>BHP</b>	 153 ▶
	8-50	<b>Bearing Pullers</b> Max. Width: 110 - 292 mm Max. Spread: 10 - 245 mm	<b>BHP</b>	 153 ▶
	2-40	<b>Posi Lock® Mechanical Pullers</b> Max. Reach: 101 - 355 mm Max. Spread: 12 - 635 mm	<b>EP EPP EPX EPPMI</b>	 154 ▶
	10-50	<b>Posi Lock® Hydraulic Pullers</b> Max. Reach: 203 - 355 mm Max. Spread: 304 - 635 mm	<b>EPH EPHR EPHS</b>	 158 ▶
	100	<b>Posi Lock® Hydraulic Pullers</b> Max. Reach: 1219 mm Max. Spread: 190 - 1778 mm	<b>EPH</b>	 161 ▶

# BHP-Series, Master Puller Sets

▼ Shown: Master Puller Set BHP-3751G



## Multi Purpose Puller Set



**WARNING**

Do not exceed 50% of the rated puller capacity when using a double crosshead (2 grip arms) or when using puller legs in combination with bearing puller attachment.

- Supplied with a full hydraulic set including pump, hose, cylinder, gauge, gauge adaptor and wooden case
- High quality, forged steel components provide superior reliability and service
- Sets include speed crank and adjusting screw for fast contact to work before hydraulics are applied
- All Master Puller Sets include a Grip Puller, a Cross Bearing Puller, a Bearing Cup Puller and a Bearing Puller Attachment, which can be ordered separately, see items nr. 10, 20, 30 and 40.

▼ Maintenance engineers throughout the industry greatly appreciate the Enerpac Master Puller sets



▼ SELECTION CHART

Master Puller Set Capacity *	8 ton	20 ton	30 ton	50 ton	Page:
Model Number ►	BHP-1752 <sup>1)</sup>	BHP-2751G	BHP-3751G	BHP-5751G	
Included Hydraulics Set Weight ►	37 kg	90 kg	172 kg	298 kg	
• Hand Pump	P-142	P-392	P-392	P-80	
• Cylinder	RWH-121	RCH-202	RCH-302	RCH-603	26 ►
• Saddle	-	HP-2015	HP-3015	HP-5016	27 ►
• Hose	HB-7206QB	HC-7206	HC-7206	HC-7206	120 ►
• Gauge	GF-120B	GF-813B	GF-813B	GF-813B	126 ►
• Gauge Adaptor	GA-4	GA-3	GA-3	GA-3	132 ►
<b>Included Pullers</b>					
<b>10</b> Grip Puller	BHP-1762	BHP-252	BHP-352	BHP-552	151 ►
<b>20</b> Cross Bearing Puller	BHP-1772	BHP-262	BHP-362	BHP-562	152 ►
<b>30</b> Bearing Cup Puller	BHP-180	BHP-280	BHP-380	BHP-580	153 ►
<b>40</b> Bearing Puller	BHP-181	BHP-282	BHP-382	BHP-582	153 ►
• Case	CM-6	CW-350	CW-350	CW-750	

<sup>1)</sup> Includes Adaptor FZ-1630.

\* See warning on this page.

# Grip Puller Sets

▼ Shown: Grip Puller Set BHP-351G



- Precise hydraulic control allows fast, efficient and safe pulling
- High quality, forged steel components provide superior reliability and service
- Available with and without full hydraulic set.

## BHP Series



Capacity:

**8, 20, 30 and 50 ton**

Reach:

**252 - 700 mm**

Spread:

**249 - 1100 mm**

Maximum Operating Pressure:

**700 bar**

### Ordering Example

#### Model Number BHP-251G:

includes Grip Puller BHP-252 and a full hydraulic set. (Hand pump, cylinder, saddle, hose, gauge and gauge adaptor).

#### Model Number BHP-252:

includes Grip Puller mechanical parts **only**, for use with your existing hydraulics.

### ▼ SELECTION CHART

Grip Puller Set Capacity **		8 ton	20 ton	30 ton	50 ton
Model Number ►		BHP-152 <sup>1)</sup>	BHP-251G	BHP-351G	BHP-551G
Included Hydraulics Set Weight ►		22 kg	56 kg	91 kg	160 kg
• Hand Pump		P-142	P-392	P-392	P-80
• Cylinder		RWH-121	RCH-202	RCH-302	RCH-603
• Saddle		-	HP-2015	HP-3015	HP-5016
• Hose		HB-7206QB	HC-7206	HC-7206	HC-7206
• Gauge		GF-120B	GF-813B	GF-813B	GF-813B
• Gauge Adaptor		GA-4	GA-3	GA-3	GA-3
<b>10</b> Grip Puller Model Number ►		<b>BHP-1762*</b>	<b>BHP-252*</b>	<b>BHP-352*</b>	<b>BHP-552*</b>
Maximum Spread (mm)	2-jaw	249	400	593	899
	3-jaw	249	499	800	1100
Maximum Reach (mm)	2-jaw	252	300	387	700
	3-jaw	252	300	387	700
Jaw (mm)	Thickness	15	20	24	30
	Width	23	27	38	39
Adjusting Screw (mm)	Thread	¾" - 16 UNF	1" - 8 UNC	1¼" - 7 UNC	1½" - 5.5 UNC
	Length	400	675	795	975
• Case		CW-166	CW-166	CW-350	CW-750

<sup>1)</sup> Includes Adaptor FZ-1630.

\* Grip Puller order number without hydraulics.

\*\* See warning on page 150.

# Cross Bearing Puller Sets

▼ Shown: Cross Bearing Puller Set BHP-361G



- Precise hydraulic control allows fast, efficient and safe pulling
- High quality, forged steel components provide superior reliability and service.

## BHP Series



Capacity:  
**8, 20, 30 and 50 ton**

Reach:  
**354 - 863 mm**

Spread:  
**266 - 570 mm**

Maximum Operating Pressure:  
**700 bar**



The cross bearing puller without hydraulics, bearing cup puller and a bearing puller can be ordered separately, see items nr. 10, 20, 30 and 40.

### ▼ SELECTION CHART

Cross Bearing Puller Set Capacity		8 ton	20 ton	30 ton	50 ton
	<b>Model Number ▶</b>	<b>BHP-162 <sup>1)</sup></b>	<b>BHP-261G</b>	<b>BHP-361G</b>	<b>BHP-561G</b>
<b>Included Hydraulics</b>	<b>Set Weight ▶</b>	26 kg	62 kg	121 kg	185 kg
• Hand Pump		P-142	P-392	P-392	P-80
• Cylinder		RWH-121	RCH-202	RCH-302	RCH-603
• Saddle		–	HP-2015	HP-3015	HP-5016
• Hose		HB-7206QB	HC-7206	HC-7206	HC-7206
• Gauge		GF-120B	GF-813B	GF-813B	GF-813B
• Gauge Adaptor		GA-4	GA-3	GA-3	GA-3
<b>20 Cross Bearing Puller <sup>2)</sup></b>	<b>Model Number ▶</b>	<b>BHP-1772</b>	<b>BHP-262</b>	<b>BHP-362</b>	<b>BHP-562</b>
Spread (mm)	Maximum	266	351	454	570
	Minimum	106	139	179	220
Reach (mm)	Maximum	462	571	711	863
Adjusting Screw (mm)	Diameter	3/4" - 16 UNF	1" - 8 UNC	1 1/4" - 7 UNC	1 5/8" - 5.5 UNS
	Length	400	675	795	975
Leg (mm)	Length	105	239	203	609
	Length	354	419	457	863
	Length	–	571	711	–
	Length	–	114	–	–
Upper Leg Ends (mm)	Thread	3/4" - 16 x 25	3/4" - 16 x 25	1-14 x 35	1 1/4" - 12 x 38
Lower Leg Ends (mm)	Thread	5/8" - 18 x 25	5/8" - 18 x 25	1-14 x 27	1 1/4" - 12 x 38
<b>30 Bearing Cup Puller <sup>2)</sup></b>	<b>Model Number ▶</b>	<b>BHP-180</b>	<b>BHP-280</b>	<b>BHP-380</b>	<b>BHP-580</b>
<b>40 Bearing Puller <sup>2)</sup></b>	<b>Model Number ▶</b>	<b>BHP-181</b>	<b>BHP-282</b>	<b>BHP-382</b>	<b>BHP-582</b>
• Wooden Case		CM-6	CW-187	CW-350	MK-05

<sup>1)</sup> Includes Adaptor FZ-1630.

<sup>2)</sup> Can be ordered separately without hydraulic components, see next page.

# Bearing Cup and Bearing Pullers

▼ Shown: **BHP-380**



## Bearing Cup Puller

- Made of high strength steel alloy
- Easily adapted to Cross Bearing Pullers for fast and efficient removal of the most difficult parts
- Adjustable to fit a variety of bearings and seals.

## BHP Series



Capacity:

**8, 20, 30 and 50 ton**

Maximum Reach:

**110 - 145 mm**

Spread Range:

**110 - 359 mm**

Maximum Operating Pressure:

**700 bar**

### ▼ SELECTION CHART

Capacity *		8 ton	20 ton	30 ton	50 ton
<b>30 Bearing Cup Puller</b>					
Model Number ▶		<b>BHP-180</b>	<b>BHP-280</b>	<b>BHP-380</b>	<b>BHP-580</b>
Spread (mm)	Max.	110	220	359	359
	Min.	26	25	50	50
Reach (mm)	Max.	110	140	145	145
	Center Screw Thread	3/4" - 16 UNF	1" - 8 UNC	1 1/4" - 7 UNC	1 5/8" - 5.5

\* Puller capacity, not attachment capacity. See warning on this page.



### WARNING

Do not exceed 50% of the rated puller capacity when using a double crosshead (2 grip arms) or when using puller legs in combination with bearing puller attachment.

▼ Shown: **BHP-382**



## Bearing Puller

- Made of high strength steel alloy
- Wedge-shaped edges allow removal of the most hard-to-grip components
- Easily adapted to Cross Bearing Pullers for fast and efficient removal of the most difficult parts.

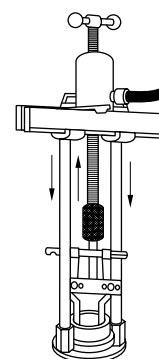

◀ Bearing Cup Puller shown with Crosshead Puller Attachment.

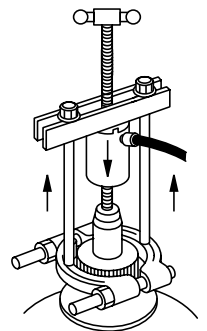

Bearing Puller shown with Crosshead Puller Attachment. ▶

### ▼ SELECTION CHART

Capacity *		8 ton	20 ton	30 ton	50 ton
<b>40 Bearing Puller</b>					
Model Number ▶		<b>BHP-181</b>	<b>BHP-282</b>	<b>BHP-382</b>	<b>BHP-582</b>
Spread (mm)	Max.	104	130	245	245
	Min.	25	9	17	17
Width (mm)		126	150	292	292
Thread		5/8" - 18 UNF	5/8" - 18 UNF	1" - 14 UNS	1 1/4" - 12 UNF

\* Puller capacity, not attachment capacity. See warning on this page.



### Bearing Puller

Bearing Puller has wedge shaped edges for placing puller behind hard to reach bearings, gears, etc., where clearance prevents direct application of grip puller arms. The Bearing Puller can be used with the Cross Bearing Puller or the Grip Puller.

▼ Shown from left to right: EP-206, EP-108



## For Safer and Faster Pulling

- Patented 'Safety Cage' jaw retention system
- Roll threaded shafts for less effort when applying high torque
- Slim tapered jaws for improved gripping in tight spots
- Available in 2 and 3 jaw design and inside and outside pulling configuration
- More efficient pulling, as one man can do the job where manual pullers often require two operators.



◀ Positioning an EP-104 3-jaw puller on the accessory drive of a diesel engine.



### Long Jaws

Long Jaws are used to increase the reach and spread of manual pullers. They maintain the same pulling capacity as the standard jaws, but reduce clamping force to 25%.

Page: 157



### Shaft Attachments

Shaft protectors and extenders are live centers that fit over the standard puller shaft for tip protection and additional reach.

Page: 157



### Application Tip

Because of the unique safety cage design, Posi Lock® pullers will grip on surfaces where normal pullers would slip off; e.g. tapered bearings.

# Posi Lock® Mechanical Grip Pullers

## External Posi Lock® Pullers

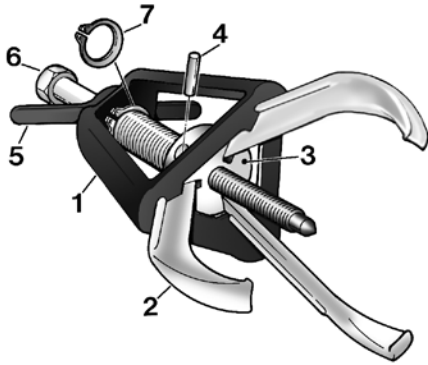

- 1 Patented 'Safety Cage' guides jaws, holding them securely onto the part.
- 2 Durable forged jaws provide positive grip.
- 3 Jaw head provides pivot and reaction point for jaws.
- 4 Pin, for easy jaw removal and replacement.
- 5 T-handle provides control of the puller jaws.
- 6 Drive bolt with rolled threads for increased force with reduced input torque.
- 7 Snap-ring retains cage to drive bolt and provides quick removal for easy service.

## EP EPP Series



Capacity:

**2 - 40 ton**

Maximum Reach:

**101 - 355 mm**

Spread Range:

**12 - 635 mm**

### ▼ QUICK SELECTION CHART EXTERNAL PULLERS

For quick technical information see next page.

Number of Jaws	Maximum Reach	Spread (min. - max.)	Capacity	Model Number	Center Bolt Diameter	
	(mm)					
2	101	12 - 127	2 (17)	EP-204	14	1,4
3	101	12 - 127	5 (45)	EP-104	14	1,8
2	152	12 - 178	6 (53)	EP-206	16	3,2
3	152	12 - 178	10 (89)	EP-106	16	3,6
2	203	19 - 304	12 (106)	EP-208	20	5,4
3	203	19 - 304	17 (151)	EP-108	20	6,4
2	245	25 - 381	14 (124)	EP-210	20	5,9
3	245	25 - 381	20 (178)	EP-110	20	7,3
2	304	63 - 457	25 (222)	EP-213	29	17,2
3	304	63 - 457	30 (267)	EP-113	29	20,0
2	355	76 - 635	35 (311)	EP-216	31	25,8
3	355	76 - 635	40 (356)	EP-116	31	30,8



### IMPORTANT!

Always wear Safety Goggles while using pullers.



### Application Tip

In determining the correct manual puller capacity for your application, use the following rule:

The center bolt diameter of the puller should be at least ½ the diameter of the shaft being pulled on.

### Example:

A part being pulled from a shaft with a diameter of 38 mm would require a puller with a center bolt diameter of at least 19 mm.

## Internal Posi Lock® Puller

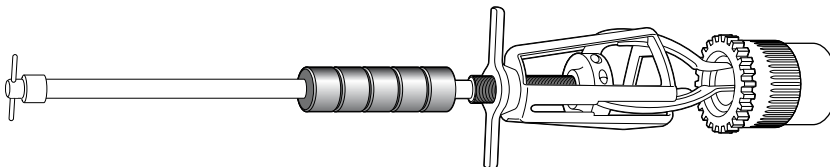

### ▼ QUICK SELECTION CHART INTERNAL PULLERS

Number of Jaws	Maximum Reach	Spread min. - max.	Jaw Style	Model Number	Jaw Length	
	(mm)					
3	168	14 - 101	Standard	EPPMI-6	168	3,9
	218	25 - 133	Long		218	3,9

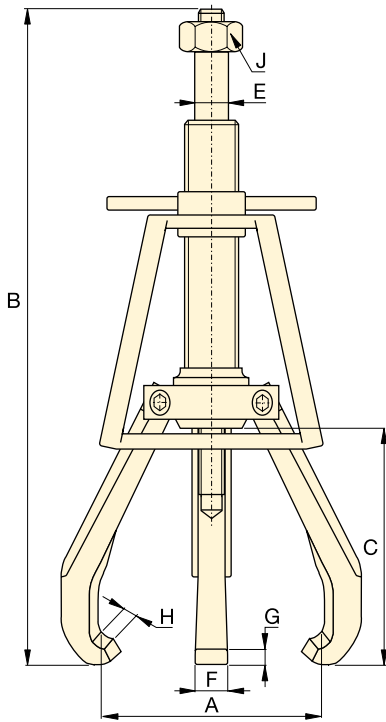

**2 and 3 Jaw External Puller  
EP-Series**

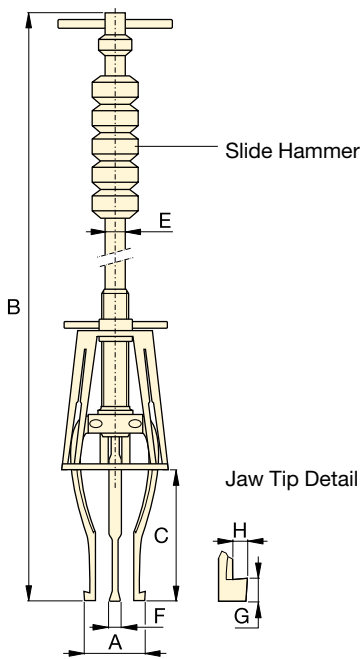

**Internal Puller  
EPPMI-6**



▲ EP-204 2 jaw puller positioned to pull a water pump drive pulley.

▼ **QUICK SELECTION CHART EXTERNAL PULLERS**

Number of Jaws	Maximum Reach (mm)	Spread min. - max. (mm)	Capacity ton (kN)	Model Number	Center Bolt Diameter (mm)	Maximum Torque (Nm)
2	101	12 - 127	2 (17)	EP-204	14	27
3	101	12 - 127	5 (45)	EP-104	14	54
2	152	12 - 178	6 (53)	EP-206	16	102
3	152	12 - 178	10 (89)	EP-106	16	176
2	203	19 - 304	12 (106)	EP-208	20	203
3	203	19 - 304	17 (151)	EP-108	20	298
2	245	25 - 381	14 (124)	EP-210	20	237
3	245	25 - 381	20 (178)	EP-110	20	373
2	304	63 - 457	25 (222)	EP-213	29	644
3	304	63 - 457	30 (267)	EP-113	29	814
2	355	76 - 635	35 (311)	EP-216	31	1085
3	355	76 - 635	40 (356)	EP-116	31	1153

▼ **QUICK SELECTION CHART INTERNAL PULLERS**

Number of Jaws	Maximum Reach (mm)	Spread min. - max. (mm)	Jaw Style	Model Number	Jaw Style (mm)	Slide-hammer weight (kg)
3	168	14 - 101	Standard	EPPMI-6	168	1,1
	218	25 - 133	Long		218	1,1

# Posi Lock® Mechanical Pullers



## Shaft Attachments

Shaft protectors and extenders are live centers that fit over the standard puller shaft for tip protection and additional reach.



## Long Jaws

Long Jaws are used to increase the reach and spread of pullers. They maintain the same pulling capacity as the standard jaws, but reduce clamping force to 25% of rating.

## EP EPP Series



Capacity:

**2 - 40 ton**

Maximum Reach:

**101 - 355 mm**

Spread Range:

**12 - 635 mm**



### ▼ SHAFT ATTACHMENTS

Length (mm)	Dia- meter (mm)	Increases Center Bolt Length (mm)	Model Number
25	19	9	<b>EPP-4</b>
50	19	38	<b>EPX-4</b>
31	22	12	<b>EPP-6</b>
50	22	38	<b>EPX-6</b>
31	25	12	<b>EPP-10</b>
50	25	38	<b>EPX-10</b>
50	35	21	<b>EPP-1316</b>

### ▼ LONG JAWS

Spread min. - max. (mm)	Max. Reach (mm)	Model Number
57 - 381	245	<b>EP-11054</b>
38 - 558	400	<b>EP-11054L</b>
38 - 762	508	<b>EP-11354L</b>
25 - 133	218	<b>EP-10554L*</b>

\* for EPPMI-6 only

Dimensions (mm)									Model Number	Optional Accessories		
Spread min. - max.  A	Overall Length  B	Max. Reach  C	Center Bolt Diam.  E	Jaw Width  F	Tip Clearance  G	Tip Depth  H	Hex Socket Size (inch) J					
12 - 127	245 - 323	101	14	15	4,1	4,6	7/8	<b>EP-204</b>	<b>EPP-4</b>	<b>EPX-4</b>	-	
12 - 127	245 - 323	101	14	15	4,1	4,6	7/8	<b>EP-104</b>	<b>EPP-4</b>	<b>EPX-4</b>	-	
12 - 178	323 - 476	152	16	19	8,1	6,1	1 <sup>11</sup> / <sub>16</sub>	<b>EP-206</b>	<b>EPP-6</b>	<b>EPX-6</b>	-	
12 - 178	323 - 476	152	16	19	8,1	6,1	1 <sup>11</sup> / <sub>16</sub>	<b>EP-106</b>	<b>EPP-6</b>	<b>EPX-6</b>	-	
19 - 304	412 - 615	203	20	22	6,4	9,1	1 <sup>1</sup> / <sub>4</sub>	<b>EP-208</b>	<b>EPP-10</b>	<b>EPX-10</b>	<b>EP-11054</b>	
19 - 304	412 - 615	203	20	22	6,4	9,1	1 <sup>1</sup> / <sub>4</sub>	<b>EP-108</b>	<b>EPP-10</b>	<b>EPX-10</b>	<b>EP-11054</b>	
25 - 381	489 - 736	245	20	25	6,4	9,1	1 <sup>1</sup> / <sub>4</sub>	<b>EP-210</b>	<b>EPP-10</b>	<b>EPX-10</b>	<b>EP-11054L</b>	
25 - 381	489 - 736	245	20	25	6,4	9,1	1 <sup>1</sup> / <sub>4</sub>	<b>EP-110</b>	<b>EPP-10</b>	<b>EPX-10</b>	<b>EP-11054L</b>	
63 - 457	660 - 965	304	29	31	12,7	9,7	1 <sup>11</sup> / <sub>16</sub>	<b>EP-213</b>	<b>EPP-1316</b>	-	<b>EP-11354L</b>	
63 - 457	660 - 965	304	29	31	12,7	9,7	1 <sup>11</sup> / <sub>16</sub>	<b>EP-113</b>	<b>EPP-1316</b>	-	<b>EP-11354L</b>	
76 - 635	800 - 1155	355	31	36	13,5	11,7	1 <sup>13</sup> / <sub>16</sub>	<b>EP-216</b>	<b>EPP-1316</b>	-	<b>EP-11654L</b>	
76 - 635	800 - 1155	355	31	36	13,5	11,7	1 <sup>13</sup> / <sub>16</sub>	<b>EP-116</b>	<b>EPP-1316</b>	-	<b>EP-11654L</b>	

Note: Overall length (B) is dependent on position of center bolt.

Dimensions (mm)							Model Number
Spread min. - max. A	Overall Length B	Max. Reach C	Slide Rod Dia. E	Jaw Width F	Tip Clearance G	Tip Depth H	
14 - 101	736	168	14,2	8	3,0	1,5	<b>EPPMI-6</b>
25 - 133	787	218	14,2	8	7,6	4,6	



Always wear Safety Goggles while using pullers.

▼ Shown: EPHR-110



- Patented 'Safety Cage' jaw retention system
- High force hydraulic system for effortless pulling of large components
- Slim tapered jaws for better gripping in tight spots
- Available in 2 and 3 jaw design
- More efficient pulling, as one man can do the job where manual pullers often require two operators.

## High-Tech Pulling



### Transport and Store

Conveniently stores and transports hydraulic pullers and accessories. Order the **EPT-2550** Storage Cart and make your job easier to do!



### Long Jaws

Used to increase the reach and spread of pullers. They maintain the same pulling capacity as the standard jaws, but reduce clamping force to 25%.

Page: 160

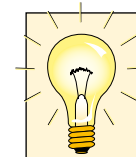

### Application Tip

Because of the unique safety cage design, Posi Lock® pullers will grip on surfaces where normal pullers would slip off; e.g. tapered bearings.



◀ EPHR-116 used to remove electric motor pulleys. Puller is positioned using the Lift Plate.

### ▼ SELECTION CHART

Number of Jaws	Maximum Spread (mm)	Capacity ton (kN)	Model Number*
2	304	10 (101)	EPH-208
3	304		EPH-108
2	381	15 (142)	EPH-210
3	381		EPH-110
2	457	25 (232)	EPH-213
3	457		EPH-113
2	635	50 (498)	EPH-216
3	635		EPH-116

\* Cylinder is not included.

# Posi Lock® Hydraulic Grip Pullers

## ▼ SETS SELECTION CHART

Style	Capacity (ton)	Basic Puller	Cylinder	Stroke (mm)	Pump Set	Set Model Number *	 (kg)
2 Jaw Puller	10	EPH-208	RC-106	152	-	<b>EPHR208</b>	10
	10	EPH-208	RC-106	152	EP-1E	<b>EPHS208E</b>	27
	15	EPH-210	RC-1510	254	-	<b>EPHR210</b>	22
	15	EPH-210	RC-1510	254	EP-1E	<b>EPHS210E</b>	38
	25	EPH-213	RC-2514	362	-	<b>EPHR213</b>	44
	25	EPH-213	RC-2514	362	EP-1E	<b>EPHS213E</b>	53
	50	EPH-216	RC-5013	336	-	<b>EPHR216</b>	87
50	EPH-216	RC-5013	336	EP-2E	<b>EPHS216E</b>	123	
3 Jaw Puller	10	EPH-108	RC-106	152	-	<b>EPHR108</b>	11
	10	EPH-108	RC-106	152	EP-1E	<b>EPHS108E</b>	28
	15	EPH-110	RC-1510	254	-	<b>EPHR110</b>	23
	15	EPH-110	RC-1510	254	EP-1E	<b>EPHS110E</b>	39
	25	EPH-113	RC-2514	362	-	<b>EPHR113</b>	48
	25	EPH-113	RC-2514	362	EP-1E	<b>EPHS113E</b>	57
	50	EPH-116	RC-5013	336	-	<b>EPHR116</b>	91
	50	EPH-116	RC-5013	336	EP-2E	<b>EPHS116E</b>	127

\* Standard set EPHS models shipped with 230 VAC pump.

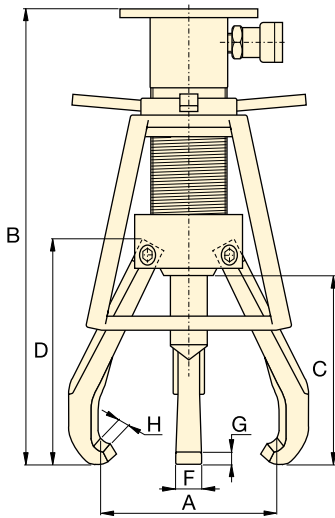

## EPH Series



Capacity:

**10 - 50 ton**

Maximum Reach:

**203 - 355 mm**

Spread Range:

**19 - 635 mm**

Maximum Operating Pressure:

**700 bar**







### Pump Sets

All Posi Lock® Hydraulic Puller Sets that include 230 VAC pumps, will feature the following components:



	EP-1E Pump Set	EP-2E Pump Set
Pump	PUJ-1200E	ZE4210ME
Hose	HC-7210	HC-7210
Gauge	G-2535L	G-2535L
Adaptor	GA-3	GA-3

Components for 115 VAC pumps are available on request.

Dimensions (mm)							 (kg)	Model Number *	Accessories <sup>1)</sup>		
Spread min. - max.	Overall Length	Maximum Reach	Jaw Length	Jaw Width	Tip Clearance	Tip Depth			Standard included	Standard included	Optional
A	B	C	D	F	G	H					
19 - 304	498	203	237	22	7,4	6,9	6,4	<b>EPH-208</b>	EPH-155	EPH-11052	<b>EP-11054</b>
19 - 304	498	203	237	22	7,4	6,9	7,3	<b>EPH-108</b>	EPH-155	EPH-11052	<b>EP-11054</b>
25 - 381	665	245	270	25	11,2	9,1	10,0	<b>EPH-210</b>	EPH-155	EPH-11052	<b>EPH-11054L</b>
25 - 381	665	245	270	25	11,2	9,1	11,3	<b>EPH-110</b>	EPH-155	EPH-11052	<b>EPH-11054L</b>
63 - 457	846	304	348	31	12,9	9,7	21,3	<b>EPH-213</b>	EPH-257	EPH-11352	<b>EPH-11354L</b>
63 - 457	846	304	348	31	12,9	9,7	25,0	<b>EPH-113</b>	EPH-257	EPH-11352	<b>EPH-11354L</b>
76 - 635	919	355	413	36	15,0	11,7	40,8	<b>EPH-216</b>	EPH-508	EPH-11652	<b>EPH-21654L</b>
76 - 635	919	355	413	36	15,0	11,7	45,4	<b>EPH-116</b>	EPH-508	EPH-11652	<b>EPH-11654L</b>

<sup>1)</sup> See next page for details.

## ▼ RAM POINT SETS SELECTION CHART

Fits Puller Set Model Number	EPH-208, EPH-210 EPH-108, EPH-110	EPH-213 EPH-113	EPH-216 EPH-116
			
Ram Point Set <sup>1)</sup> Model Number	<b>EPH-155</b>	<b>EPH-257</b>	<b>EPH-508</b>
Ram Points Included:	Ram Point Dimensions Diameter x Length (mm)		
Flat Ram Points	ø25 x 25	ø38 x 57	ø51 x 76
	ø25 x 76	ø51 x 57	ø70 x 76
	–	ø51 x 102	ø70 x 127
Tapered Ram Points	ø25 x 38	ø38 x 64	ø51 x 95
	ø25 x 89	ø51 x 64	ø51 x 95
	–	ø51 x 114	ø70 x 140
Ram Point Adaptor	–	–	ø70 x 57

<sup>1)</sup> Standard included in EPH-Series Posi Lock Pullers.

## EPH Series



Capacity:

**10 - 50 ton**

Maximum Reach:

**38 - 762 mm**

Spread Range:

**246 - 508 mm**



**IMPORTANT!**

Always wear Safety Goggles while using pullers.

## ▼ LIFT PLATE SELECTION CHART

Fits Puller Set Model Number	Model Number *	Thick-ness (mm)	Dia-meter (mm)
EPH-208	EPH-11052	6,4	ø153
EPH-108	EPH-11052	6,4	ø153
EPH-210	EPH-11052	6,4	ø153
EPH-110	EPH-11052	6,4	ø153
EPH-213	EPH-11352	9,7	ø203
EPH-113	EPH-11352	9,7	ø203
EPH-216	EPH-11652	9,7	ø254
EPH-116	EPH-11652	9,7	ø254

\* Mounting screws included. Lifting plates are standard included with EPH-Series Pullers.

## ▼ LONG JAW SELECTION CHART

Fits Puller Set Model Number	Model Number	Number of Jaws required	Spread (mm)	Reach (mm)	 (kg)
EPH-208	EP-11054	2	57 - 381	246	1,1
EPH-108	EP-11054	3	57 - 381	246	1,1
EPH-210	EPH-11054L	2	38 - 559	401	2,5
EPH-110	EPH-11054L	3	38 - 559	401	2,5
EPH-213	EPH-11354L	2	38 - 762	508	4,8
EPH-113	EPH-11354L	3	38 - 762	508	4,8
EPH-216	EPH-21654L	2	50 - 965	635	7,5
EPH-116	EPH-11654L	3	50 - 965	635	7,5



Long Jaws are optional accessories and used for added reach and spread. They have the same load capacity as standard jaws with 25% of the clamping force.

# Posi Lock® 100 Ton Hydraulic Grip Pullers

▼ EPH-1003E



**EPH Series**



Capacity:  
**100 ton**

Maximum Reach:  
**1219 mm**

Spread Range:  
**190 - 1778 mm**

Maximum Operating Pressure:  
**700 bar**

- Roller cart with power lift
- Hydraulically actuated lift cylinder on cart extends puller from ground to a height of 1,69 m
- Adjustable jaw tips
- Includes electric one stage pump with remote pendant for fingertip control of the removal process
- Puller height range 673 to 1690 mm
- Multiple pushing adaptors included.

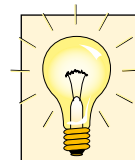

**Pushing Adaptors**

All Posi Lock® 100 Ton Hydraulic Pullers include following pushing adaptors.

Diameter (mm)	Length (mm)	Model Number
89	737	<b>EPHT-1162</b>
89	483	<b>EPHT-1163</b>
89	229	<b>EPHT-1164</b>



◀ The EPH-1002E quickly and easily removes this drive coupler from its shaft.

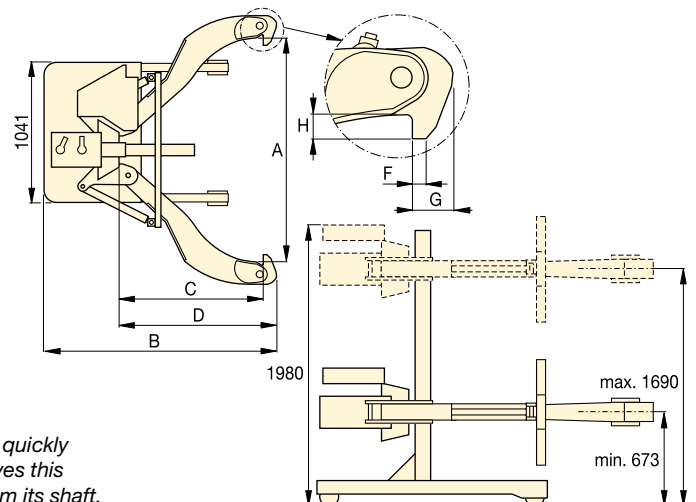

Number of Jaws	Spread Range A (mm)	Capacity ton (kN)	Model Number	Cylinder Stroke (mm)	Overall Length B (mm)	Reach C (mm)	Jaw Length D (mm)	Jaw Width F (mm)	Tip Clearance G (mm)	Tip Depth H (mm)	 (kg)
2	190 - 1778	100 (980)	<b>EPH-1002E</b>	250	1955	1219	1346	32	89	89	771
3	190 - 1778	100 (980)	<b>EPH-1003E</b>	250	1955	1219	1346	32	89	89	907