

Enerpac Hydraulic Presses

ENERPAC 
POWERFUL SOLUTIONS. GLOBAL FORCE.

انعام صنعت

Enerpac Hydraulic Presses are available in a variety of capacities and sizes. The press frames are designed for maximum strength and durability. Strong frames and powerful high-pressure hydraulics will provide years of dependable service in many applications.

Enerpac Presses are available in Bench, C-Frame, Arbor, Workshop and Roll-Frame models.

These Press features increase productivity and broaden the range of applications:

Side-to-side cylinder movement

Lateral movement capability of cylinder in upper bed.

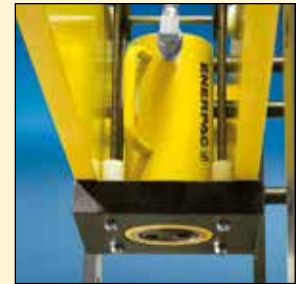

Press Kits

The 50 and 75 ton XLP-Series presses come as unassembled kits, and include complete press frame, winch, cylinder, pump with gauge, couplers and hose.











Winch

Movable upper and lower bed with self-braking winch on XLP-Series presses.



Hydraulic Presses Section Overview

Capacity ton (kN)	Press type and functions	Series		Page
10 (101)	Bench Presses	VLP		138 ▶
25 - 200 (232 - 1995)	Workshop Presses	XLP VLP		138 ▶
50 - 200 (498 - 1995)	Roll-Frame Presses	BPR		140 ▶
5 - 20 (45 - 178)	C-Clamp Presses	A		142 ▶
10 - 30 (101 - 295)	Arbor Presses	A		142 ▶
5 (44,5)	Hydraulic Bench Vise	BV		144 ▶
10 - 200 (101 - 1995)	Press Accessories Press Application Idea	VB, A, IPL		146 ▶
900 - 90.000 kg	Tension Meters Load Cells	TM LH		147 ▶

Available in capacities from 10 to 200 ton, each Enerpac press consists of three basic high quality components: a press frame, a power source and a cylinder.

Press Frame

Press frames include features like workpiece side-loading and height adjustment of the upper and lower bed.

Power Source

Depending on the production requirements, Enerpac presses can be powered by manual, air-hydraulic and electric-drive power sources.

Cylinder

Depending on the application, double-acting cylinders offer increased efficiency. Check out the Selection Charts for the press best suited for your needs.

Gauge

All Workshop presses and Roll-Frame Presses feature an easy to monitor pressure/force gauge for increased safety.



IMPORTANT!

The frameworks of the workshop presses are exclusively designed for pressing operations, not for pulling. For pulling applications please contact Enerpac.

In order to fully comply with CE regulations, some presses must be equipped with specific safety components, such as spring centered valves, two-hand control devices, guards or others.

Enerpac standard general purpose presses are supplied without guards, and have a plunger speed of less than 10 mm/second. However, your application may require that measures should be taken to reduce the risk of injury to operators and other personnel by providing appropriate safeguarding, training and conducting a risk assessment, which eliminates or reduces danger.

Health & safety within your workplace is your responsibility, not that of Enerpac.

Advice on such matters is available from your local enforcement agency. If you require any further information on Enerpac accessories that may help you conform to the Machinery Directive or European legislation contact Enerpac.



Bench and Workshop Presses

▼ From left to right: XLP-506XA12G, XLP-256XA11G



No Workshop can do without one



XA-Series Foot Pump

The XLP-press with XA-Series air powered foot pump: no need to fully lift up foot – rest bodyweight on heel, resulting in a handsfree and stable working position – safe and controlled press operation (see page 100 for XA-Series Pumps).



Press Kits *

The 50 and 75 ton presses come standard as unassembled kits, and include complete press frame, winch, cylinder, pump with gauge, couplers and hose.



Easy grip forklift access

Cut-away in lower frame for pallet truck access allows easy transportation of 50 and 75 ton XLP-series presses.

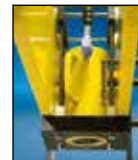

Side-to-side cylinder movement



Cylinder can be positioned horizontally side-to-side on all XLP-Series presses.

- All presses equipped with long life Golden Ring Design cylinder
- XLP-Series presses**
- Multi-functional presses in kit form (50 and 75 ton presses)
- Easy grip forklift access on 50 and 75 ton presses
- Height adjustment of upper or lower bed with winch (50 & 75 ton)
- Width adjustment allows cylinder to move from side-to-side
- Pump options include XA-Series air-operated foot pump
 - pressure gauge integrated in pump for optimal control
 - suitable for delicate pressing jobs from variable oil flow.

VLP-Series presses

- Unique “Hydrajust” bed positioning device on 100 and 200 ton VLP-presses allows adjustment of the lower bed.

▼ SELECTION CHART

Press Capacity ton (kN)	Maximum Daylight (mm)		Press Model Number	Power Source					Cylinder						
	Vertical	Horizontal		Pump Type			Valve Type		Pump Model Nr.	Page:			Stroke (mm)	Cylinder Model Nr.	Page:
				Man.	Elec.	Air	Man.	Elec.							
10 (101)	430	432	VLP-106P142	●			●		P-142	66	●		156	RC-106	6
	430	432	VLP-106PAT1			●	●		PATG-1102N	102	●		156	RC-106	6
25 (232)	1225	510	XLP-256P392	●			●		P-392	66	●		158	RC-256	6
	1225	510	XLP-256XA11G			●	●		XA-11G	100	●		158	RC-256	6
50 (498)	993	990	XLP-506P802 *	●			●		P-802	68	●		159	RC-506	6
	993	990	XLP-506XA12G *			●	●		XA-12G	100	●		159	RC-506	6
	993	990	XLP-506ZES *		●			●	ZE4410SE-E050	92		●	156	RR-506	32
	993	990	XLP-5013ZES *		●			●	ZE4410SE-E050	92		●	334	RR-5013	32
75 (718)	989	990	XLP-756XA12G *			●	●		XA-12G	100	●		156	RC-756	32
100 (933)	989	990	VLP-1006ZES		●			●	ZE5420SW-E050	92		●	168	RR-1006	32
	989	990	VLP-10013ZES		●			●	ZE5420SW-E050	92		●	333	RR-10013	32
200 (1995)	1340	1220	VLP-20013ZES		●			●	ZE6420SW	92		●	330	RR-20013	32

* 50 and 75 ton XLP-Series presses can be ordered as factory assembled press frame. Add suffix “M” to press model number. Example: XLP-506XA12G-M.



= Single-Acting



= Double-Acting

Bench and Workshop Presses

Optional V-Blocks

To facilitate positioning of pipes and bars, or placed upside-down, to serve as a convenient worktable.

Featuring precise fit into the press bolster. Each model number includes two V-blocks.

To be used with press (ton)	V-Blocks Model Number
10	VB-10
25	VB-25
50	VB-501
75, 100	VB-101
200	A-200

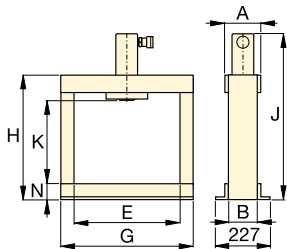

VLP 10 ton

"Hydrajust" Bed Positioning

Allows vertical adjustment of the lower bed on 100 and 200 ton VLP presses.

IMPORTANT: The "Hydrajust" bed positioning is not designed to withstand full cylinder capacity, only to be used for bed adjustment.

Page: 146

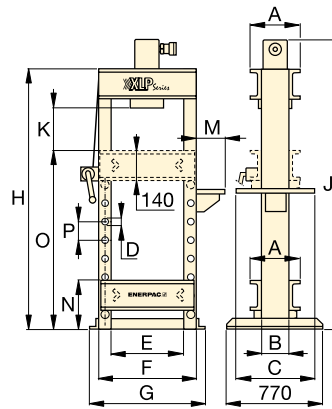

XLP 25 ton

XLP, VLP Series



Capacity:

10 - 200 ton

Maximum Daylight x Width:

1340 x 1220 mm

Maximum Operating Pressure:

700 bar



IMPORTANT!

The frameworks of the workshop presses are exclusively designed for pressing operations, not for pulling. For pulling applications please contact Enerpac.

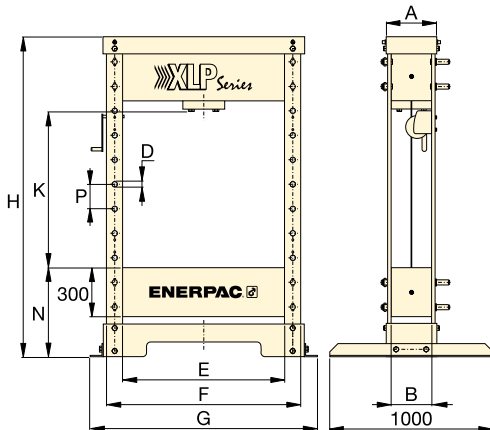

XLP 50 and 75 ton

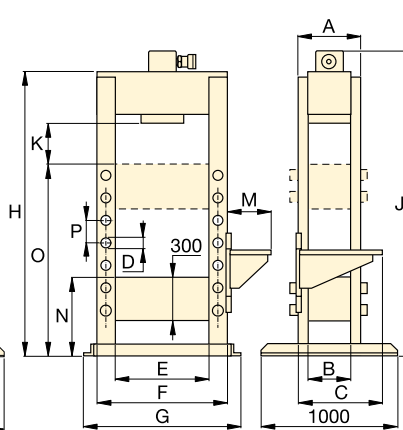

VLP 100 ton

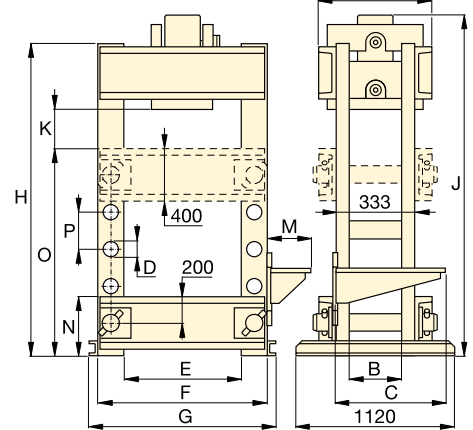

VLP 200 ton

Speed (mm/s) **		Dimensions (mm)															Press Model Number
Rapid Advance	Pressing	A	B	C	D	E	F	G	H	J	K	M	N	O	P	(kg)	
{2,5} **	{0,6} **	110	80	-	-	432	-	542	620	748	430	-	80	-	-	49	VLP-106P142
10,0	1,8	110	80	-	-	432	-	542	620	748	430	-	80	-	-	54	VLP-106PAT1
{3,4} **	{0,7} **	260	140	510	32	510	630	700	1622	1740	370	140	212	1070	122	165	XLP-256P392
10,0	1,3	260	140	610	32	510	630	700	1622	1740	370	323	212	1070	122	170	XLP-256XA11G
{5,5} **	{0,3} **	310	240	-	32	990	1190	1390	1995	-	210-940	-	540	-	150	595	XLP-506P802 *
4,7	0,6	310	240	-	32	990	1190	1390	1995	-	210-940	-	540	-	150	600	XLP-506XA12G *
10,0	2,0	310	240	-	32	990	1190	1390	1995	-	210-940	-	540	-	150	660	XLP-506ZES *
10,0	2,0	310	240	-	32	990	1190	1390	1995	-	210-940	-	540	-	150	700	XLP-5013ZES *
3,2	0,4	420	330	-	40	990	1240	1430	1995	-	210-940	-	540	-	150	900	XLP-756XA12G *
10,0	2,1	400	340	560	40	990	1240	1400	1879	1885	239	425	540	1290	150	970	VLP-1006ZES
10,0	2,1	400	340	560	40	990	1240	1400	1879	2050	239	425	540	1290	150	993	VLP-10013ZES
6,6	1,6	553	233	560	76	1220	1620	1740	2285	2370	377	425	453	1415	254	1992	VLP-20013ZES

** {...} = advance speed in mm per handpump stroke.

BPR-Series, Roll-Frame Presses

▼ Shown: BPR-5075



Expert Designed Versatility

- Quality welded frame for maximum strength and long life
- Frame rolls easily on 4 steel roller bearings
- Exclusive 'Hydra-Lift' bolster for effortless adjustment of the vertical daylight
- Roller head design is standard to allow lateral movement and locking of the cylinder up to 300 mm left or right of centre
- All models in the quick selection chart have been matched to an electric pump, double-acting cylinder, hose and gauge, offering the complete package
- Roll-Frame design features a stationary bed with the ability to support heavy loads.



Cylinder adjustment

Cylinder adjustment allows horizontal side to side cylinder positioning.



Hydra-Lift

Allows easy, effortless daylight adjustment. Standard on all Roll-Frame presses.

Page: 146



Optional V-Blocks

These V-Blocks are designed for easy fixturing of round stock and other non-uniform materials. Featuring precise fit into the press bolster.

Page: 146

▼ SELECTION CHART

Press Capacity ton (kN)	Vertical Daylight A (mm)		Maximum Bed Width E (mm)	Electric Pump		Press Model Number	Double-Acting Cylinder			Speed (mm/sec)	
	min.	max.		Model Number	Page		Stroke (mm)	Model Number	Page	Rapid Advance	Pressing
50 (498)	152	942	730	ZE5420SW-S	92	BPR-5075	334	RR-5013	32	4,1	3,9
100 (933)	159	1048	889	ZE3420SW	92	BPR-10075	333	RR-10013	32	7,7	0,7
200 (1995)	279	1295	1219	ZE4420SW	92	BPR-20075	330	RR-20013	32	5,2	0,5

Roll-Frame Presses



▲ A BPR-20075 Roll-Frame Press is used to remove a large shaft from this pillow-block assembly. The Roll Frame design allows this heavy part to be safely loaded with an overhead crane.

BPR Series



Capacity:
50 - 200 ton

Maximum Daylight x Width:
1295 x 1222 mm

Maximum Operating Pressure:
700 bar



IMPORTANT!

The frameworks of the presses are exclusively designed for pressing operations, not for pulling. For pulling applications please contact Enerpac.

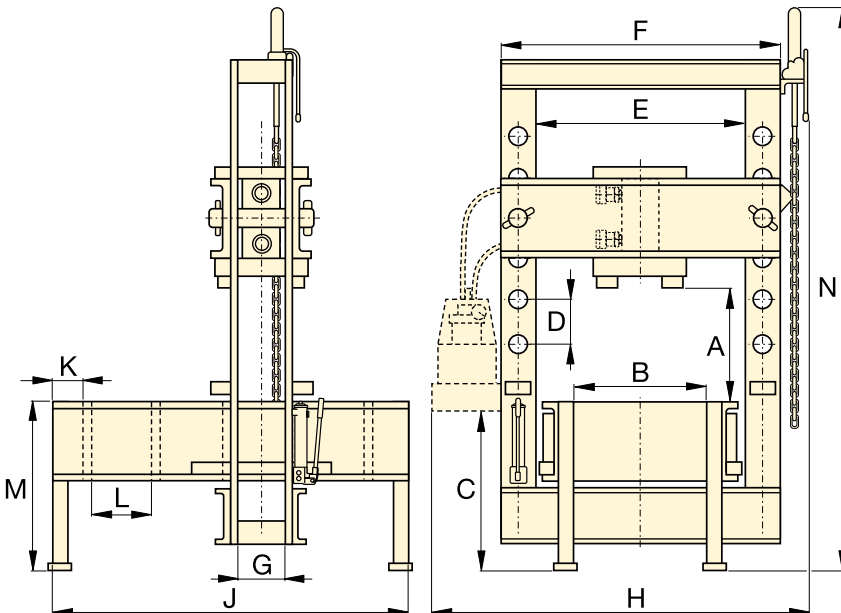

Gauges

All press models include a gauge and gauge adaptor, matching the press capacity:

Press Capacity	Gauge Model Number	Adaptor Model Number
ton		
50	GF-50B	GA-2
100	GF-871B	GA-3
200	GF-200B	GA-3

For more information on gauges, please refer to the System Components section.

Page: 126

Roll-Frame Press Dimensions (mm)													Press Model Number	
A (min.-max.)	B	C	D	E	F	G	H	J	K	L	M	N		(kg)
152 - 942	526	971	264	730	933	127	1420	1626	203	270	762	2870	917	BPR-5075
159 - 1048	673	965	222	889	1143	146	1605	1676	203	270	813	3021	1767	BPR-10075
279 - 1295	984	933	254	1219	1626	232	2150	2197	203	381	915	3200	4186	BPR-20075

▼ Shown from left to right: A-220, A-330 and A-310



The Standard Workshop Tools

C-Clamp Press

- 5, 10 and 20 ton capacity
- Operational in all positions.

Arbor Press

- 10 and 30 ton capacity
- Foot mounting holes for horizontal or vertical positioning
- Machined working surfaces for easier fixturing
- Slotted back to simplify loading and unloading of longer parts.

▼ A-310 Arbor Press used for compacting powder at 10 ton.



Push Pin A-183

For applications requiring precision pressing, such as shaft removal and insertion. This attachment fits 10 ton cylinders and requires the use of a threaded adaptor saddle (A-13).

Page: 166



Hydra-Lift

Allows easy, effortless daylight adjustment. Standard on all Roll-Frame presses.

Page: 167



10 ton Bench Presses

For 10 ton VLP-Series Bench Presses selection see:

Page: 138

▼ SELECTION CHART

Press Type	Press Capacity ton (kN)	Maximum Vertical Daylight (mm)	Maximum Bed Width (mm)	Press Model Number	Cylinder Model Number *	Page:
C-Clamp	5 (45)	165	51	A-205	5 ton RC-cylinder*	6
	10 (101)	228	57	A-210	10 ton RC-cylinder*	6
	20 (178)	305	70	A-220	25 ton RC-cylinder**	6
Arbor	10 (101)	227	135	A-310	10 ton RC-cylinder*	6
	30 (295)	260	178	A-330	RC-308*	6

* Recommended cylinder must be ordered separately.

** Must be limited to 20 ton.

C-Clamp and Arbor Presses



▲ A perfect example of the force and versatility of the Enerpac A-220 C-Clamp press.

A Series



Capacity:
5 - 30 ton

Maximum Daylight x Width:
305 x 178 mm

Maximum Operating Pressure:
700 bar



IMPORTANT!

For high-cycle production applications, the C-Clamp and Arbor presses should be limited to 50% of their capacity.

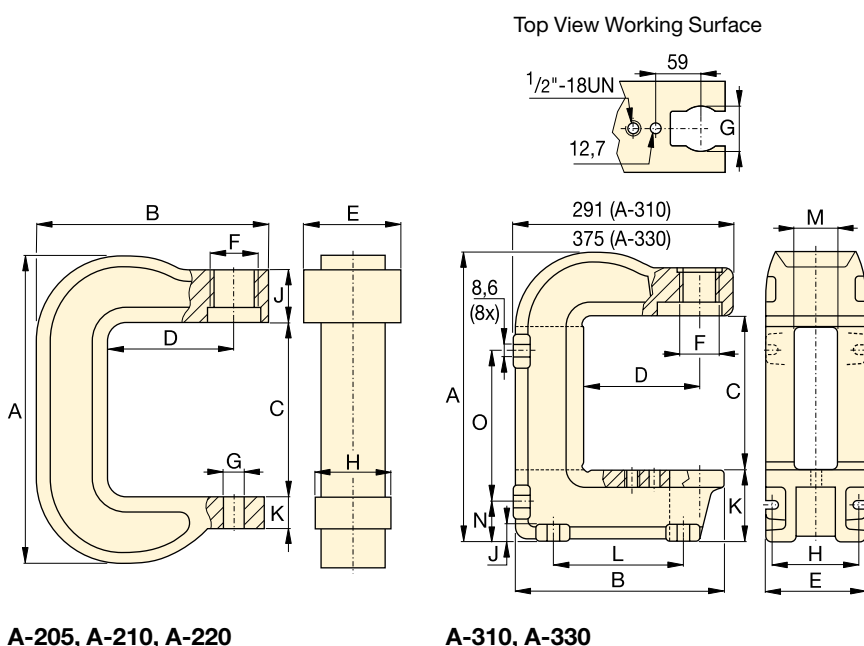

A-205, A-210, A-220

A-310, A-330



Hydraulic Cylinders

Cylinders for C-Clamps and Arbor Presses must be ordered separately.

Page: 6



Hydraulic Pumps

Pumps for C-Clamps and Arbor Presses must be ordered separately.

Page: 65

Press Dimensions (mm)															Press Model Number
A	B	C	D	E	F	G	H	J	K	L	M	N	O	(kg)	
291	203	165	95	73	1½" -16 UNS	26	51	66	25	-	-	-	-	7	A-205
406	283	228	152	83	2¼" -14 UNS	26	76	64	41	-	-	-	-	17	A-210
540	346	305	152	108	3⅝" -12 UNS	26	95	70	44	-	-	-	-	38	A-220
414	281	227	152	135	2¼" -14 UNS	63	122	19	97	175	65	54	219	27	A-310
557	353	260	152	178	3⅝" -12 UNS	63	140	25	165	203	67	98	276	86	A-330

BV-Series, Hydraulic Bench Vise

▼ Shown: BV-5 Hydraulic Bench Vise



- 44,5 kN of force for forming and pressing applications
- 203 mm jaws hold large objects, making cumbersome tasks into one-person jobs
- Hands-free operation for safe and controlled actuation when paired with PA-133 air-powered foot pump
- Flexible-use and ergonomically-friendly tool mounts as a press vertically or as a bench vise horizontally with a swivel base
- Rapid spring return makes repetitive work faster
- Accessory Magnetic Jaw Liners free hands by holding sockets, screws, rings, c-clips, springs, etc.

Safe, controlled, hands-free clamping



Hydraulic Bench Vise Sets

Order everything needed in one box to start working. The BV-5 Hydraulic Bench Vise is available as a set (pump, coupler and vise with hose).

Set Model Number	Vise Model Nr.	Pump Model Nr.	Coupler Model Nr.
STV-5PA	BV-5 *	PA-133	CR-400

* Includes hose HC-7206.

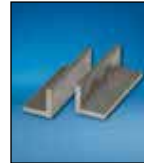

Magnetic Jaw Liners

Don't forget to order **BV-5VC** Magnetic Jaw Liners. The magnet inserts hold steel objects like sockets, screws and rings.

Accessories must be ordered separately.

Model Number

BV-5VC



◀ Enerpac BV-5 Hydraulic Bench Vise mounted vertically for high-force pressing applications

► Enerpac BV-5 Hydraulic Bench Vise with hands-free PA-133 Foot Pump makes work with a large heavy piece into a one person job.



Hydraulic Bench Vice



Hydraulic Bench Vice

The Hydraulic Bench Vice is a general purpose tool that can have multiple clamping and holding applications. Its hydraulic cylinder applies force of up to 5 ton, three-to-five times the force of a manually operated vise. Hydraulic pressure closes the vise, and spring-return opens the jaws.

The Hydraulic Bench Vice can be installed horizontally on a flat surface, vertically as a press, or in any other orientation that satisfies the safety criteria stipulated by the operators' manual.

BV Series



Maximum Force:

44,5 kN

Maximum Jaw Opening:

203 mm

Jaw Width:

203 mm

Maximum Operating Pressure:

700 bar

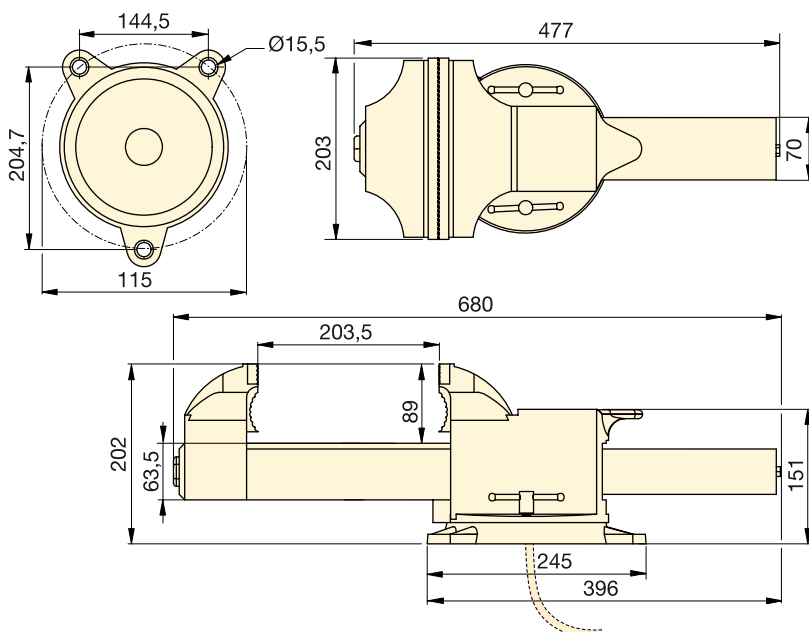



▼ Enerpac BV-5 Hydraulic Bench Vice with hands-free PA-133 Foot Pump for safe and controlled actuation.



▼ SELECTION CHART

Maximum Force at 700 bar	Model Number	Oil Capacity	Height	Jaw Width	Jaw Opening (Fully Open)	Length (Jaws Closed)	Length (Jaws Open)	Weight (Vise only)
ton (kN)		(cm ³)	(mm)	(mm)	(mm)	(mm)	(mm)	(kg)
5 (44,5)	BV-5	131	202	203	203	477	680	25

Description	Press Capacity and Press Series	Model Number		Features
V-Blocks	10 ton Bench VLP-Presses 25 ton Workshop XLP-Presses 50 ton Workshop XLP-Presses 75 ton XLP- and 100 ton VLP-Presses 200 ton Workshop VLP-Press 200 ton BPR-Roll-Frame Press	VB-10 VB-25 VB-501 VB-101 A-200 A-200R		<ul style="list-style-type: none"> Facilitate positioning of pipes and bars All V-Block model numbers include 2 V-blocks.
Hydra-Lift	50 ton BPR-Roll-Frame Press 100 ton BPR-Roll-Frame Press 200 ton BPR-Roll-Frame Press	IPL-R100 IPL-R100 IPL-R200		<ul style="list-style-type: none"> Allows easy, effortless daylight adjustments Includes accessory chain.
Hydrajust Bed Positioning	100 ton Workshop VLP-Presses 200 ton Workshop VLP-Press IMPORTANT! The “Hydrajust” bed positioning is not designed to withstand full cylinder capacity, only to be used for bed adjustment.	VHJ-100 BSS-5380		<ul style="list-style-type: none"> Allowing effortless daylight adjustment by moving the lower bed up and down Can be used with presses equipped with double-acting cylinder.

▼ PRESS APPLICATION IDEAS



◀ 600 Ton High-Accuracy Collar Press

For production of accelerator coils, sheet metal needs to be formed into a specific shape and size. The end product of this forming is a cylindrical collar, which has a very solid structure, specific shape, and a tight tolerance for circularity and concentricity.

The Enerpac team was consulted to accomplish this task using proven high-pressure technology. The 600-ton press consisted of two separate hydraulic systems. The first system featured eight 25-ton cylinders, to position the sheets, while the second system featured eight 75-ton cylinders, to press the sheets into the correct shape. The results were a hydraulic press system that increased productivity and lowered operating costs.

Fully Automated PLC-Controlled 1800 Ton High-Accuracy Press ▶

The pressing and heating cycle, during the production of magnetic acceleration coils, required high force and high-accuracy to ensure absolute quality.

Enerpac was consulted to assist in the design of a high accuracy production press. Control of the press force is monitored along with the temperature of the coils during forming by a PLC Control System.



Tension Meter and Load Cells

▼ Shown: LH-102 and TM-5 (in middle)



TM LH Series

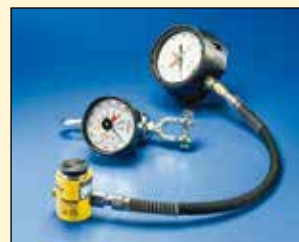

Capacity:

900 - 90.000 kg

Accuracy, % of full scale:

± 2%



TM and LH models are 100% tested to verify accuracy within a ± 2% range.

If your application requires a calibrated tool, it must be submitted for certification testing. Certification is NOT available from Enerpac.

Tension Meter TM-5

- Accuracy ± 2% of full scale
- Zinc and bronze plated to resist corrosion
- Dual-range readout in kilograms and pounds
- Maximum indicating pointer reading for pre-selected forces or to maintain force readings
- Cushioned metal case provides safe storage and transport.

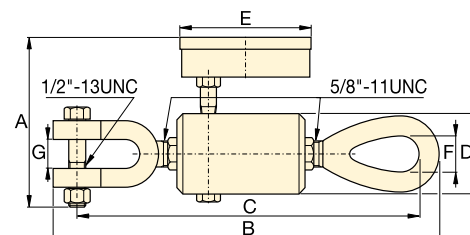

TM-5

Load Cells LH-Series

- Accuracy ± 2% of full scale
- Swivel loading pad reduces eccentric loading for improved accuracy
- Maximum indicating pointer reading pre-selected forces or to maintain maximum force readings
- Dual-range readout in kilograms and pounds.

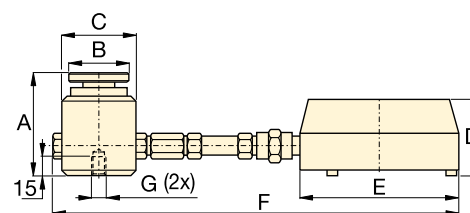

LH-Series

▼ SELECTION CHART

Type	Gauge Capacity		Model Number	Minimum Reading		Gauge Scale Increments		Dimensions (mm)						
	(kg)	(lbs)		(kg)	(lbs)	(kg)	(lbs)	A	B	C	D	E	F	G*
Direct Mounted	4.500	10.000	TM-5	500	1.000	100	100	120	247	236	50	93	22	19
Direct Mounted Load Cell	900	2.000	LH-10	100	200	20	20	77	44	57	60	101	215	¼" - 20, 44,5 BC
	4.500	10.000	LH-50	500	1.000	100	100	77	44	57	60	101	215	¼" - 20, 44,5 BC
Remote Mounted with 0,6 m Hose	900	2.000	LH-102	100	200	20	20	77	44	57	60	147	846	¼" - 20, 44,5 BC
	4.500	10.000	LH-502	500	1.000	100	100	77	44	57	60	147	846	¼" - 20, 44,5 BC
	9.000	20.000	LH-1002	1.000	2.000	200	200	77	44	57	60	147	846	¼" - 20, 44,5 BC
Remote Mounted with 1,8 m Hose	21.000	50.000	LH-2506	3.000	5.000	500	500	101	69	85	60	147	2094	¾" - 24, 63 BC
	45.000	100.000	LH-5006	5.000	5.000	1.000	1.000	132	101	127	60	147	2135	¾" - 24, 89 BC
	90.000	200.000	LH-10006	10.000	10.000	1.000	2.500	158	127	158	60	147	2166	¾" - 24, 102 BC

* BC = Bolt Circle